

OpenAir™

VAV Compact Controller

G..B181.1E/3



VAV compact controller 5 / 10 Nm

- GDB181.1E/3 with 5 Nm nominal torque
- GLB181.1E/3 with 10 Nm nominal torque
- Operating voltage AC 24 V
- Supports 0...10 V or 2...10 V control and feedback signals
- For plants with variable or constant air volume flow
- Operating modes for continuous air volume flow control, 3-position control (open loop), or step control
- Actual values for air volume flow or damper position selectable
- Override control to close-off in 2...10 V control signal operation

Type summary

Type	Stock no.	Operating voltage	Control / feedback signal	Power consumption	Runtime	Manual adjuster	Position feedback
GDB181.1E/3	BPZ:GDB181.1E/3	AC 24 V	0...10 V	3 VA / 2,5 W ¹⁾	150 s	Yes	Yes
GLB181.1E/3	BPZ:GLB181.1E/3		or 2...10 V	1 VA / 0,5 W ²⁾			

¹⁾ Running

²⁾ Holding

Version history

Product version	Production period	Major changes
Series E	03/2012 – 01/2016	<ul style="list-style-type: none"> New dp sensor 2...10 V signal option
Series F	01/2016 – 10/2020	<ul style="list-style-type: none"> Close-off function in 2...10 V operation
Series G	10/2020 - 05/2023	<ul style="list-style-type: none"> Extensions in OEM parameters
Series H	From 10/2023	<ul style="list-style-type: none"> Update of priorities for communication objects, see basic documentation

Ordering (example)

Type	Stock no.	Description	Amount
GDB181.1E/3	GDB181.1E/3	VAV Compact Controller	1

Accessories / Spare parts

See data sheet **N4698**.

Equipment combinations

Type	Stock no.	Description	Data sheet ID
AST20	S55499-D165	Handheld tool for commissioning and service	A6V10631836
AST22	S55499-D373	USB/PPS2 Interface converter	A6V11236956
ACS931 ¹⁾	-	PC Software for OEMs	N5853
ACS941 ¹⁾	-	PC software for Service	N5854

¹⁾ The ACS931 and ACS941 PC software can be downloaded at the following Internet address:
<https://support.industry.siemens.com>
 Availability of ACS931 is limited to OEM customers.



Product documentation

Title	Topic	Document ID
OpenAir™ VAV compact controller G..B181.1E/3, VAV modular controller ASV181.1E/3	Technical Basics	P3544
Mounting instructions VAV compact controller	Mounting and installation instructions	M3544
Accessories and Spare Parts for Air Damper Actuators ASK..	Data sheet; accessories and spare parts for air damper actuators type GDB../GLB..	N4698

Related documents such as environmental declarations, CE declarations, etc., can be downloaded at the following Internet address:

<http://siemens.com/bt/download>

Notes

Safety

CAUTION



National safety regulations

Failure to comply with national safety regulations may result in personal injury and property damage.

- Observe national provisions and comply with the appropriate safety regulations.

Commissioning



VAV compact controllers are not suitable for environments, where the air is saturated with sticky or fatty particles or contains aggressive substances.

Mounting

Do not open the VAV compact controllers.

NOTICE



Do not use the accessory mounting holes for mounting the VAV compact controller.

Doing so can damage the VAV compact controller.

- Use anti-rotation-bracket for mounting the controller instead.
- See mounting instructions M3544.

IP54 protection in the following mounting positions:

⚠ IP54

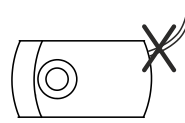
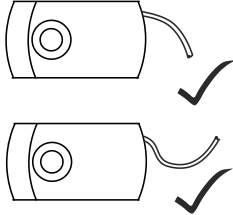
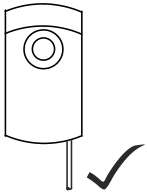

Accessory mounting holes

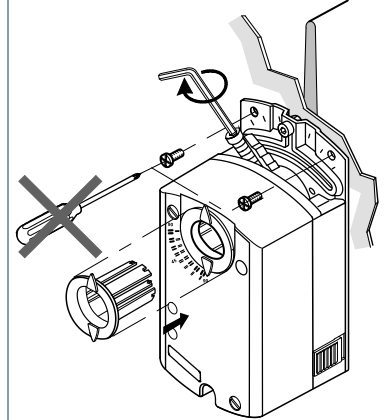

Maintenance

- The VAV compact controllers are amaintenance-free.
- Disconnect the electrical connections from the terminals if you need to service the device.

⚠ CAUTION



Risk of injury from electric shock

There is a risk of injury from electric shock when using the gear train disengagement slider to manually adjust the actuator.

- The actuator must be in a de-energized state during manual adjustments.

Disposal



The device is considered an electronic device for disposal in accordance with European Directive and may not be disposed of as domestic waste.

- Use only designated channels for disposing the devices.
- Comply with all local and currently applicable laws and regulations.

Device components

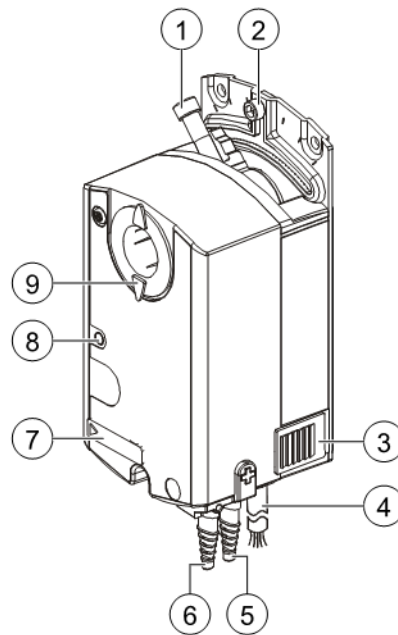

- 1 Shaft attachment screw
- 2 Set screw for rotation angle limitation
- 3 Gear train disengagement slider
- 4 6-core connecting cable (power and communications)
- 5 Connection nozzle for measuring differential pressure in the VAV box ("+": side with higher pressure)
- 6 Connection nozzle for measuring differential pressure in the VAV box
- 7 Configuration and maintenance interface (under cover)
- 8 LED
- 9 Rotation angle indicator

LED colors and patterns

Color	Pattern	Description
Off	-	Device not powered
Green	Steady	Device is running
Red	Flashing	Connection tubes for sensor interchanged
	Steady	Differential pressure sensor fault

Parametrization (with AST20 or AST22)

For the OEM factory programming or commissioning/maintenance directly on the VAV compact controller a suitable tool (see Equipment combinations [▶ 2]) can be connected directly to the PPS2 interface.

Connection to the PPS2 interface	
<p>The diagram shows a parametrization tool (1) connected to the VAV compact controller (2) through a 7-pin cable (4) and a cable strain relief (3). The tool has a screen and several buttons. The controller has a circular port for the cable connection.</p>	1 AST20 (or PC with ACS931 / ACS941 via AST22)
	2 G..B181.1E/3, or ASV181.1E/3
	3 Cable strain relief
	4 Connecting cable (7-pin)

Parametrizing the VAV application

The VAV compact controllers are parametrized via configuration tools, see Equipment combinations [► 2].

The VAV compact controllers are pre-configured by the OEM via the PPS2 interface (with AST20 or ACS931). Some parameters can be changed during commissioning, operation, or maintenance.

Parameter	Range ¹⁾	Description	Factory setting
Operating mode	CON (VAV operation) / 3P (pos. control) / STP (step control)	Interpretation of setpoint <ul style="list-style-type: none"> • CON = continuous setpoint for air volume flow [%] • 3P = 3-position setpoint for damper position • STP = Min-Mid-Max control for volume flow 	CON / VAV mode
Opening direction (DIR)	r / L (cw / ccw)	Opening direction of air damper	r (cw)
Adaptive positioning (ADP)	Off / On	Adaption of actual opening range to position feedback 0...100 % <ul style="list-style-type: none"> • Off = No Adaption / 0...90° → 0...100 % • On = Pos. adaption / mapping, e.g. 0...60° → 0...100 % 	Off
Range YC signal	0...10 V / 2...10 V	Setpoint for air volume flow	0...10 V (CON / VAV mode)
Range U signal	0...10 V / 2...10 V	Actual value, according to selected U	0...10 V
U signal	FLW / POS	Actual value (measured) <ul style="list-style-type: none"> • FLW = Air volume flow [%] • POS = Damper position [%] 	FLW
Time constant U	0.05...5 s	Smoothing constant actual value U	1 s
Vnom	0...60,000 m ³ /h	Nominal air volume flow	100 m ³ /h
Vmin	-20...100 %	Minimum air volume flow	0 %
Vmid	0...100 %	Mid air volume flow (only for STP mode)	50 %
Vmax	20...120 %	Maximum air volume flow	100 %
Box coefficient (Vn value)	1...3.16	Characteristic value for air volume flow at nominal differential pressure; set by the VAV box manufacturer.	1.00
Elevation asl	0...5000m in 500 m (100 m) increments	Altitude level correction factor for differential pressure sensor	500 m

¹⁾ Values in brackets indicate any deviating specifications for AST20.

Operating modes

Operating mode CON / VAV - variable air volume control

Variable air volume control (VAV): The operating point is determined by the setpoint (DC 0...10 V or DC 2...10 V signal at YC input) and the Vmin / Vmax settings.

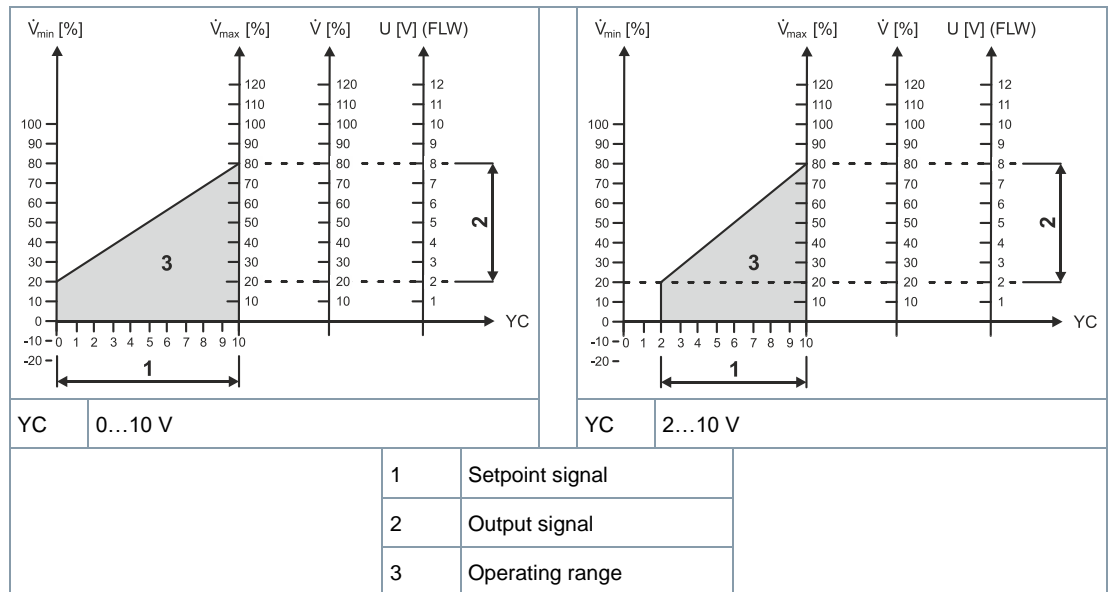

Override control in VAV / VVS mode with Y1 and Y2 inputs

Using the Y1 and Y2 control signals, the damper of the air volume controller can be driven either to the fully open or fully closed position, overriding the setpoint.

Operating mode VAV (CON / VAV)				
YC	DC 0/2...10 V			
Y1	Open	G0		Open
Y2	Open		G0	
Action	VAV control with DC 0/2...10 V setpoint	DIR r → rotates cw DIR L → rotates ccw Damper opens fully	VAV control with DC 0/2...10 V setpoint	DIR r → rotates ccw DIR L → rotates cw Damper closes fully



The actuator can also be driven to "fully closed" by setting $V_{min} \leq 0\%$ and $YC = 0\text{ V}$.

Override control with YC = 0 V for setpoint range 2...10 V

When the setpoint signal range (YC) is set to DC 2...10 V, the actuator can be driven to "fully closed" by setting YC = 0 V. The hysteresis behavior is shown in the diagram below.

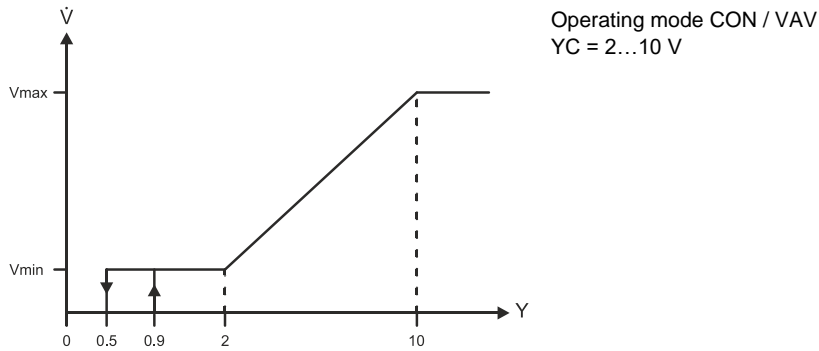

A full closure by setting YC = 0 V in 2-10 V operation overrides the inputs Y1 and Y2.

Operating mode CON / VAV – constant air volume control

Constant air volume control (CAV) is achieved if the input YC is open, or by sending a constant setpoint. Vmin and Vmax control can be accomplished with control signals Y1 and Y2.

Override control in operating mode CON / VAV

If the inputs Y1 and Y2 are wired appropriately, the states listed below can be reached:

Operating mode CAV (CON / VAV)				
YC	Open			
Y1	Open	G0		Open
Y2	Open		G0	
Action	Vmin control	DIR r → rotates cw DIR L → rotates ccw Damper opens fully	Vmax control	DIR r → rotates ccw DIR L → rotates cw Damper closes fully



CAV mode is also possible by preselecting a constant setpoint via input YC. Setting **Vmin ≤ 0 %** drives the actuator to position "fully closed".

Operating mode 3P - open loop control

To use VAV compact controllers as 3-position actuators with air volume flow measurement, the parameter "operating mode" must be set to "3P". In this operating mode, air volume flow control by the VAV compact controllers is deactivated and the parameters Vmin, Vmid, and Vmax have no effect. The damper opening direction is determined by the connection of signal inputs Y1 and Y2.

Differential pressure sensor with 3-position actuator in operating mode 3P				
YC	Open			
Y1	Open	G0		Open
Y2	Open		G0	
Action	Damper holds position	DIR r → rotates cw DIR L → rotates ccw Damper opens	DIR r → rotates ccw DIR L → rotates cw Damper closes	DIR r → rotates ccw DIR L → rotates cw Damper closes

Operating mode STP - step control

CAV step mode: CLOSE / Vmin / Vmid / Vmax / OPEN

CAV step control in operating mode STP				
YC	< 1 V → Vmin			
	Open → Vmid			
	> 9 V → Vmax			
Y1	Open	G0		Open
Y2	Open		G0	
Action	CAV step control	DIR r → rotates cw DIR L → rotates ccw Damper opens fully	CAV step control	DIR r → rotates ccw DIR L → rotates cw Damper closes fully



Setting **Vmin ≤ 0 %** drives the actuator to position "fully closed" (see Connection diagrams [▶ 14]).

Technical data

Power supply			
Operating voltage		AC 24 V \pm 20 % (SELV) or AC 24V class 2 (US)	
Frequency		50 Hz / 60 Hz	
Power consumption	at 50 Hz	Rotating	3 VA / 2.5 W
		Holding	1 VA / 0.5 W

Function data			
Runtime for nominal rotation angle 90°		150 s (50 Hz) 125 s (60 Hz)	
Torque	Nominal	GDB181.1E/3	5 Nm
		GLB181.1E/3	10 Nm
	Maximum	GDB181.1E/3	<7 Nm
		GLB181.1E/3	<14 Nm
Rotation angle	Nominal	90°	
	Maximum	95° \pm 2°	
Rotation direction		Clockwise (cw) / Counter-clockwise (ccw) (adjustable by tool)	

Inputs		
YC	(core 8)	Air volume flow reference or communication signal
	Input voltage	DC 0/2...10 V
	Max. permissible input voltage	DC 35 V
Y1 Y2	(core 6) (core 7)	Reference signals – contact sensing
	Contact open	DC 30 V contact voltage
	Contact closed	DC 0 V, 8 mA contact current
U	(core 9)	Air volume flow measuring signal
	Output voltage	DC 0/2...10 V limited to DC 12 V
	Max. output current	DC \pm 1 mA

Connecting cable		
Cable length		0.9 m
Power supply / communication	Cores and cross-sectional area	6 x 0.75 mm ²
Configuration and service interface	Terminal strip	7-pin, grid 2.00 mm

Degree of protection and safety class	
Degree of protection	IP54 as per EN 60529 (see mounting instructions)
Safety class	III to EN 60730

Environmental conditions		
Applicable standard		IEC 60721-3-x
Operation	Climatic conditions	Class 3K5
	Mounting location	Indoors
	Temperature	0...50 °C
	Humidity (non-condensing)	5...95 % r.h.
Transport	Climatic conditions	Class 2K3
	Temperature	-25...70 °C
	Humidity	5...95 % r.h.
Storage	Climatic conditions	Class 1K3
	Temperature	-5...45 °C
	Humidity	5...95 % r.h.

Directives and standards		
Product standard		EN 60730-x
Product family standard		EN 50491-3, EN 50491-5 General requirements for Home and Building Electronic Systems (HBES) and Building Automation and Control Systems (BACS)
Electromagnetic compatibility (field of use)		For residential, commercial and industrial environments
EU conformity (CE)	GDB181.1E/3	A5W00003842 ¹⁾
	GLB181.1E/3	A5W00000176 ¹⁾
UK conformity (UKCA)	GDB181.1E/3	A5W00198029A ¹⁾
	GLB181.1E/3	A5W00198019A ¹⁾
RCM conformity	GDB181.1E/3	A5W00003843 ¹⁾
	GLB181.1E/3	A5W00000177 ¹⁾
EAC compliance		Eurasia compliance for G..B181.1E/3
UL, cUL	AC 24 V	UL 873 http://ul.com/database ; file no. E35198

Environmental compatibility
The product environmental declaration A6V10209938 ¹⁾ contains data on environmentally compatible product design and assessments (RoHS compliance, materials composition, packaging, environmental benefit, and disposal).

Dimensions and weight		
Weight	Without packaging	0.6 kg
Dimensions		71 x 158 x 61 mm
Suitable damper shafts		
	Round (with centering element)	8...16 mm (8...10 mm)
	Square	6...12.8 mm
	Min. shaft length	30 mm
	Max. shaft hardness	<300 HV

Air volumen flow controller		
Type	3-position controller with hysteresis	
Vmax, adjustable	20...120 %	
	Resolution	1 %
	Factory setting	100 %
Vmin, adjustable	-20...100 %	
	Resolution	1 %
	Factory setting	0 %
Vn = f(dp _n), adjustable	1.0...3.16	
	Resolution	0.01
	Factory setting	1.00

Differential pressure sensor		
Connection tubes	(inner diameter)	3...8 mm
Measuring range		0...500 Pa
Operating range		0...300 Pa
Precision at 23 °C, 966 mbar and any mounting position		
	Zero point	± 0.2 Pa
	Amplitude	± 4.5 % of the measured value
	Drift	± 0.1 Pa/yearr
Max. permissible operating pressure		3000 Pa
Max. permissible overload on one side		3000 Pa

¹⁾ The documents can be downloaded from <http://siemens.com/bt/download>

Internal diagram

The VAV compact controllers are supplied with a pre-wired connecting cable. All interconnected devices must be connected to the same G0.

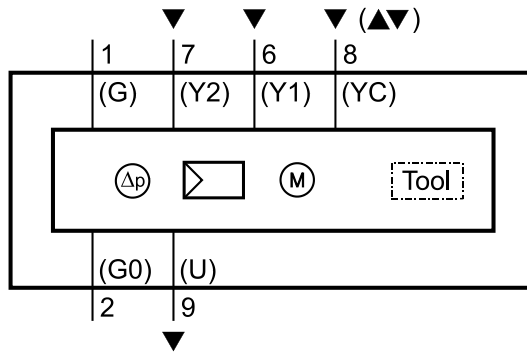

Tool = Configuration and service interface
(from Series E: use 7-pin plug)

Cable designations

No.	Code	Color	Abbreviation	Meaning
Cable 1: black sheathing				
1	G	Red	RD	System voltage AC 24 V
2	G0	Black	BK	System neutral AC 24 V
6	Y1	Purple	VT	Positioning signal "actuator's rotation direction" (G0 switched), dependent on the rotation direction setting
7	Y2	Orange	OG	Positioning signal "actuator's rotation direction" (G0 switched), dependent on the rotation direction setting
8	YC	Grey	GY	Air volume flow reference signal DC 0/2...10 V (setpoint) or communication signal
9	U	Pink	PK	Air volume flow measuring signal DC 0/2...10 V (actual value)



For connections at the configuration and service interface, note that voltages > 10 V at YC cannot be processed.

To ensure the functions at YC, only one cable may be connected at a time; either the cable for the air volume flow reference signal DC 0/2...10 V (setpoint), or the cable for the communication signal.

⚠ CAUTION



Device under voltage

- the operating voltage at terminals G and G0 must comply with the requirements for SELV or PELV.
- Safety transformers with double insulation as per EN 61558 are required; they must be designed for 100 % duty.

Operating mode CON / VAV

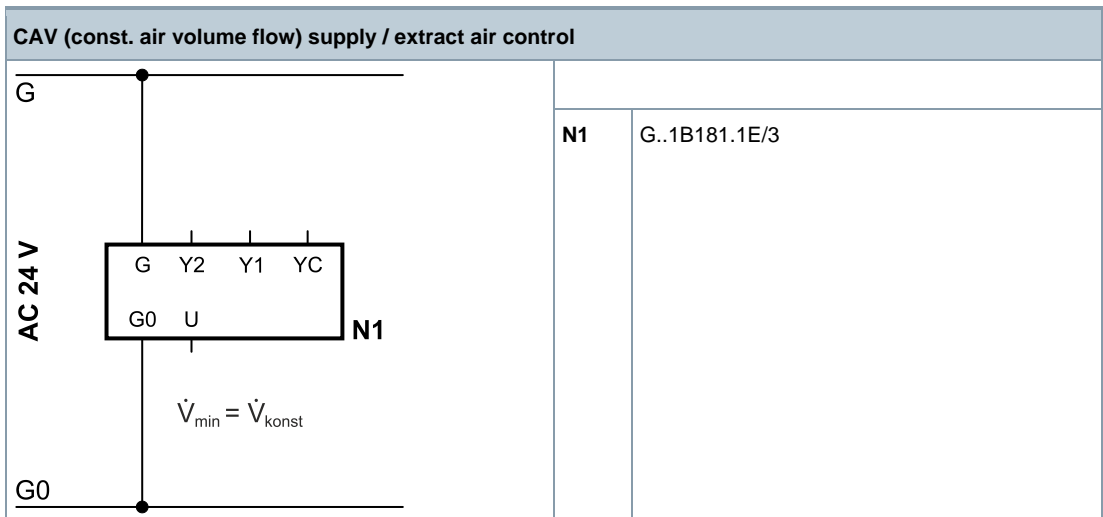
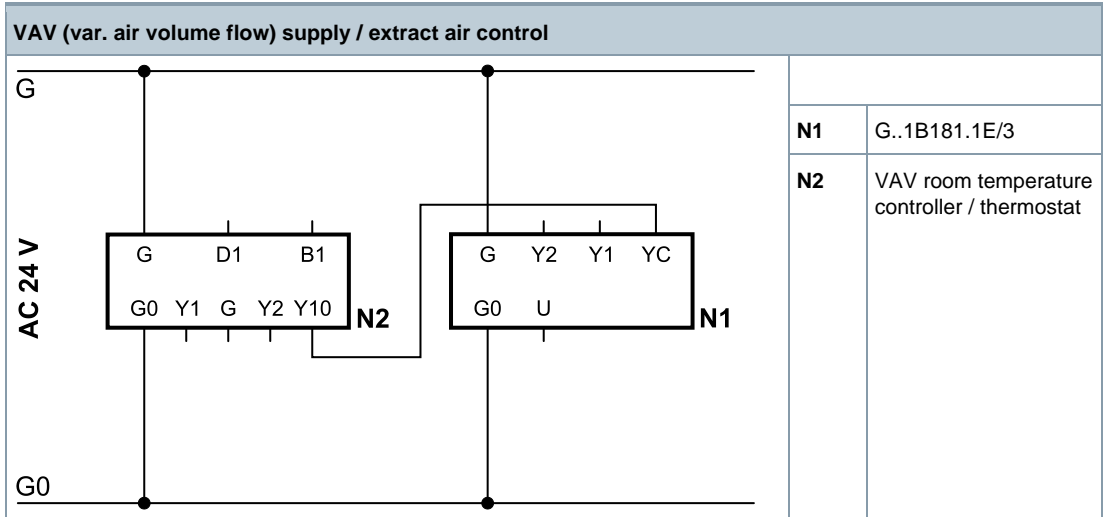

Complete close-off with Y1/Y2 inputs

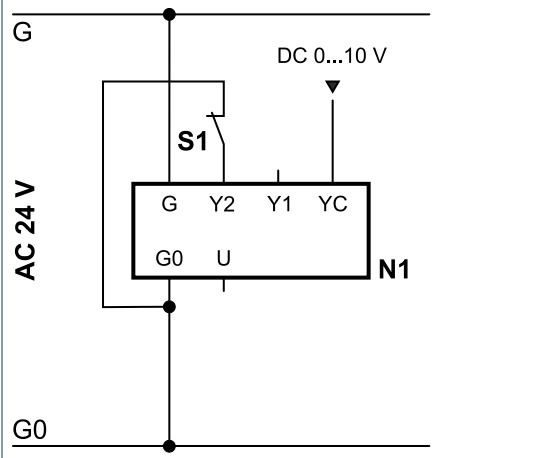

N1	G..1B181.1E/3
S1	Window contact (Window closed – contact open)

Operating mode 3P (Actuator)

Supply / extract air control

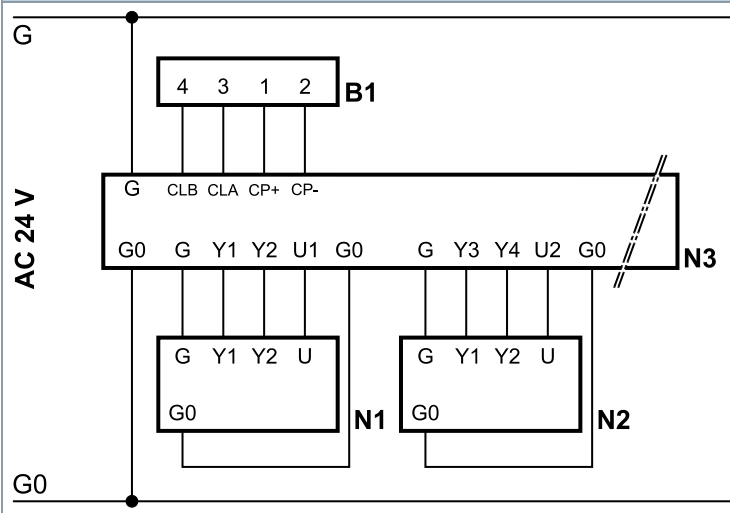

N1	G..B181.1E/3 (supply air)
N2	G..B181.1E/3 (extract air)
N3	Room temperature controller
B1	Room unit

Operating mode STP (step control)

Supply / extract air control

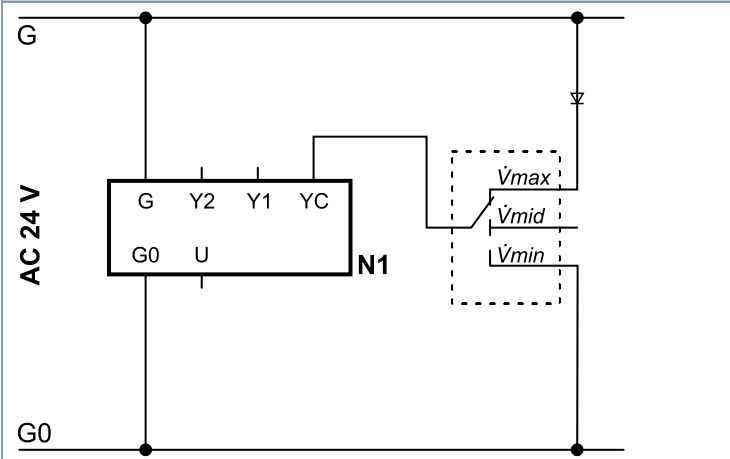

N1	G..B181.1E/3
-----------	--------------

Dimensions

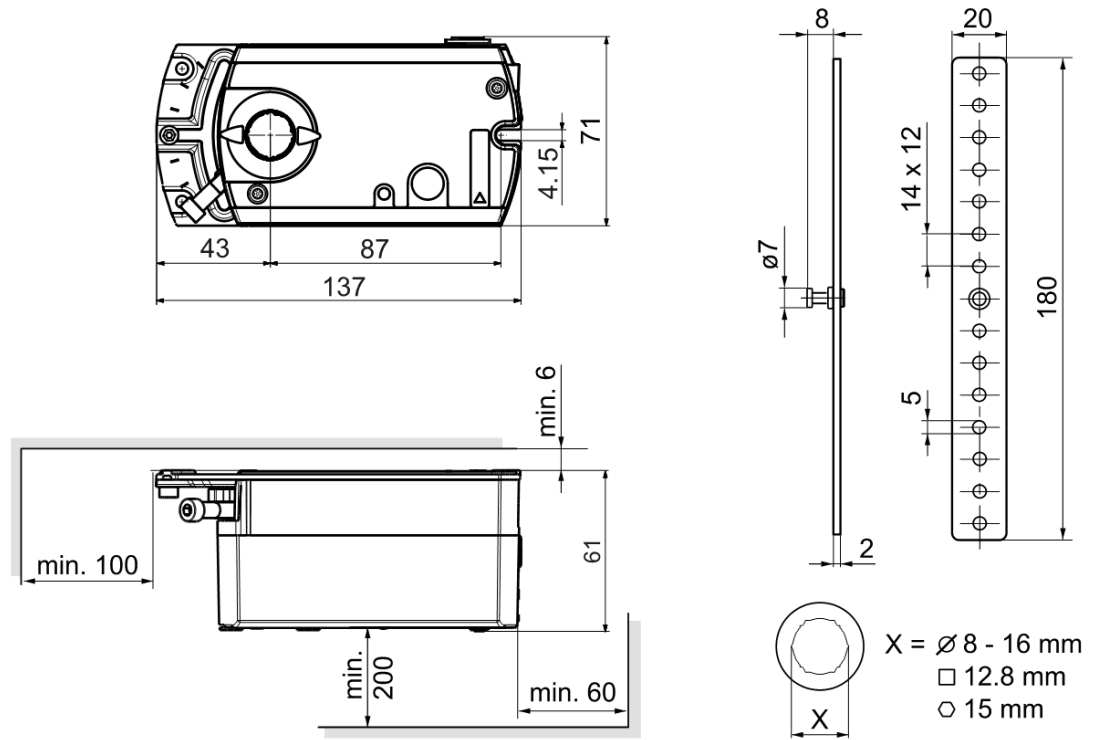

Dimensions in mm