

KNX/DALI Gateway Twin N 141/31
 KNX/DALI Gateway Twin plus N 141/21
 KNX/DALI Gateway plus N 141/03

5WG1141-1AB31
 5WG1141-1AB21
 5WG1141-1AB03

Product and function description



Fig. 1 KNX/DALI Gateway Twin plus N 141/21



The KNX/DALI Gateway is a DALI-2 certified device. It has successfully completed the DALI-2 certification process operated by DiiA. ***

This document provides information on the full range of functions for the KNX/DALI Gateway Twin plus N 141/21 - 983411 (Firmware V12). The range of functions of N 141/03 - 983711 (Firmware V12) is limited to channel A. The N 141/31 - 983D11 (Firmware V12) is function limited. The functions common to all devices are described starting on page 3 and the selectable functions starting on page 8.

A table with an overview of the functions for each KNX/DALI Gateway is on the page 6.

*** This applies only if the DALI-2 logo is printed on the device

A new firmware version if necessary can be loaded to the gateway over KNX. For additional information, please see www.siemens.com/gamma-td → Additional software → Firmware download tool

These KNX/DALI Gateways are KNX devices TP1-256 type with two independent DALI interfaces. Up to 64 DALI actuators (e.g. ECG with DALI interface) and additional DALI sensors (e.g. DALI key interface, presence detectors, etc.) can be connected per channel.

DALI (Digital Addressable Lighting Interface) is a bidirectional communications interface to IEC 62386, whose specification was chosen by manufacturers for electronic ballasts. It not only receives, for example, switching and dimming commands, but also transmits status information such as failure of an illuminant or reporting of a detected error in the ballast. The KNX/DALI Gateways enable communication with up to 64 DALI actuators per channel. These can be connected and dimmed in groups. They also make it possible to record and transfer DALI status and error messages. An individual name, a group, parameter and scenes are assigned to individual DALI ECG during commissioning with the ETS (Engineering Tool Software). DALI sensors are also assigned to groups in the ETS (for this, go to the application program description).

The integrated power supply unit supplies the gateway electronics and generates the DALI bus voltage. It facilitates operation of the gateway and direct switching and dimming of all DALI ECG's controlled via the DALI interface, even if the gateway has still not been operated with the ETS or if communication via KNX is interrupted. For this, the devices have a key (figure 2, A3) on the front to disable or enable "Direct Mode". If the key is first held down, then the display (A5) indicates direct mode by "d". Then, all lights are switched on/off (tap the key) or dimmed (hold the key down) together by the key pair (A7 and A8) and controlled by the DALI bus line via the respective channel A or B. The LED (A4) indicates the switched status of the connected lights. If the "Direct Mode" key is held down for a second time, then the "d" in the display goes out and the Gateway is again in bus mode [display b] or in standalone mode, if KNX communication is unavailable.

The devices have a voltage detector during initialization, which detects whether a voltage has been applied to the DALI terminals incorrectly.

The DALI power supply feeds both ECG and sensors; verify that the maximum permissible current drain by all connected DALI devices is not exceeded.

KNX/DALI Gateway Twin N 141/31	5WG1141-1AB31
KNX/DALI Gateway Twin plus N 141/21	5WG1141-1AB21
KNX/DALI Gateway plus N 141/03	5WG1141-1AB03

DALI fundamentals

The universal DALI bus (DALI = Digital Addressable Lighting Interface) is a system for controlling electronic switching devices (ECG) in lighting systems. The DALI communication interface specification is set out in the international IEC 62386 standard.

DALI not only receives switching and dimming commands. Additionally, status information for lighting values or error states, such as the failure of a light or an ECG, can be reported via DALI. Sensors with DALI interface are also supported. In a single DALI line, up to 64 individual DALI switching devices (slaves) can be connected through the associated controller/gateway (master). On DALI commissioning, ECGs receive an automatically generated address and in the further commissioning process a short address from 0..63 based on this address. As the address is assigned automatically, the equipment configuration is also random and the individual ECGs/lights must first be identified as the commissioning continues.

Individual ECGs in the system are addressed either on the basis of the short address (individual controller) or on the basis of a DALI group address (group addressing). For this purpose, any number of ECG's in a line can be arranged in up to 16 DALI groups. The group addressing in the DALI system ensures that a system's different light switching and dimming processes are performed concurrently without any time differences.

In addition to the addressing using short addresses and group addresses, lighting values for individual DALI ECGs can also be aggregated in scenes and contacted via scene addressing.

You will find further information on DALI, for example in the DALI manual at: www.dali-alliance.org

DALI-2 fundamentals

The DiiA has a DALI-2 certification program, which aims to improve the interoperability between DALI devices. The KNX/DALI Gateway has successfully completed this DALI-2 certification process.

You will find further information on DALI-2 at: www.dali-alliance.org ***

***This applies only if the DALI-2 logo is printed on the device.

Gateway fundamentals

The KNX/DALI Gateway communicates with up to 64 DALI actuators per channel. These can be connected and dimmed in up to 16 groups per channel. The gateway also supports selected sensors with DALI interface. It also records and transfers DALI status and error messages. An individual name, a group, parameter and scenes are assigned to individual DALI ECG's during commissioning with the ETS (Engineering Tool Software). DALI sensors and their functionality are also assigned in the ETS. All DALI subscribers and functions are independent and can be linked via group addresses.

The device can only be operated in DALI segments with connected ECGs and sensors and not with further DALI controllers within the segment (no multi-master mode). The power needed for ECGs and sensors is supplied directly through the gateway. An additional DALI power supply is not required, neither is it permitted.

Connection example

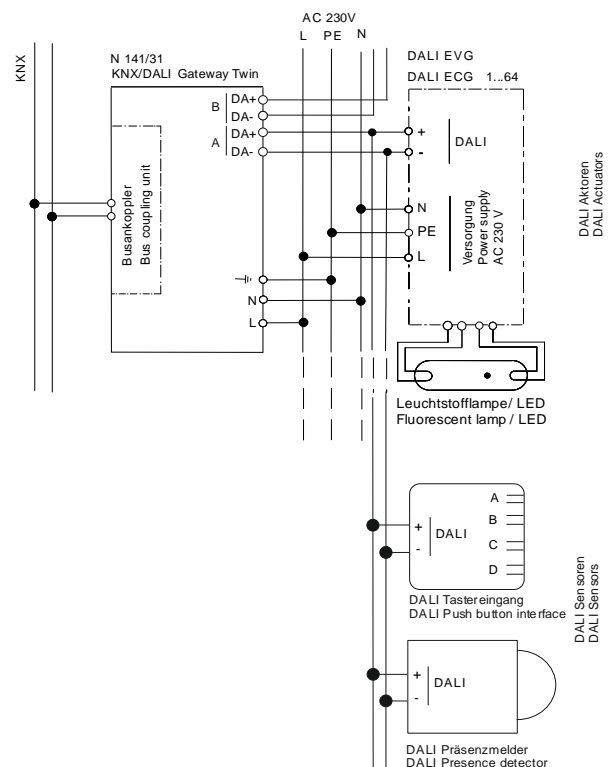

Fig. 2 Connection example for N 141/31

KNX/DALI Gateway Twin N 141/31	5WG1141-1AB31
KNX/DALI Gateway Twin plus N 141/21	5WG1141-1AB21
KNX/DALI Gateway plus N 141/03	5WG1141-1AB03

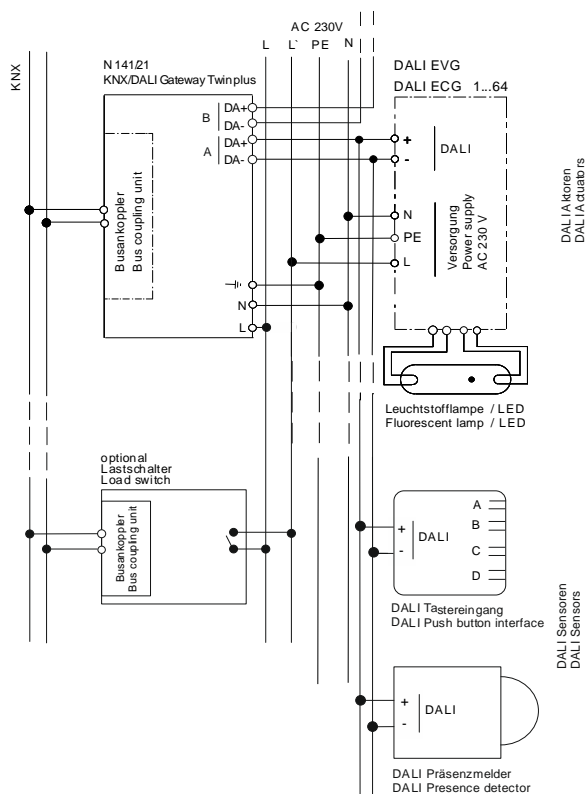

Fig. 3 Connection example for N 141/21 with stand-by shut-down (N 141/03 without channel B)

Functional overview of all devices

The device can be operated with ETS from 5 and upwards. The described functions apply for firmware version V12. The current firmware can be accessed on the device's info display (see Operating and Assembly Manual - BMA).

Application program

- 07 B0 KNX / DALI Gateway Twin 983D11
- 07 B0 KNX / DALI Gateway Twin plus 983411
- 07 B0 KNX / DALI Gateway plus 983711

The device's firmware can be loaded using KNX, additional information: www.siemens.com/gamma-td.

The type and number of communication objects are determined by the number of connected DALI devices

(ECGs, sensors and functions), the configured groups and the functions and objects enabled via the parameter window.

The configuration steps for start-up can be prepared "off-line" without a connection to the Gateway. Configuration, storage and documentation are implemented within the ETS or the parameters (plug-in). No additional files should be backed up or archived.

Modes

The gateway supports various modes, each of which is related to the device or to the group.

Normal mode (Bus mode)

In normal mode, ECGs can be connected and dimmed in groups without any restrictions. Three communication objects (switching, dimming and set value) also control each group.

A group assignment can be made only to a maximum of one DALI group. Multi-group assignments are not supported as a DALI group, but must be implemented as required by assigning KNX communication objects.

Isolated status objects provide information about the switching- and value status of the groups.

Broadcast

The DALI channel Broadcast mode controls all connected ECGs simultaneously via the Broadcast commands provided by DALI. Sensors are not included. The Works function is enabled with broadcast ex works!

Standalone mode

In standalone mode, the device can be operated without a connection to KNX. The configuration, which was loaded with ETS, is executed in standalone mode.

Direct mode

In direct mode, direct on/off switching and dimming are possible on the device.

Night mode (timed surface lighting)

Night mode can be enabled or disabled via an optionally selectable object (1-bit). If night mode is enabled for the group, then this channel can only be switched on at certain times (surface lighting). The switched on period during night mode can be varied by a parameter.

Constant light

The group is switched on permanently at the set value. All other parameters, up to the behavior if there is a bus voltage failure, cannot be adjusted. However, status objects are available.

KNX/DALI Gateway Twin N 141/31	5WG1141-1AB31
KNX/DALI Gateway Twin plus N 141/21	5WG1141-1AB21
KNX/DALI Gateway plus N 141/03	5WG1141-1AB03

Timer mode

A timer mode can be started by an ON telegram, a dim telegram (brighter/darker) or a dimming value telegram. "Time switch 1-level" is dimmed after the switched-on time has elapsed. If "Time switch 2-level" is set, the interim value is dimmed (i.e. the dimming value after the dimming time set after the switched on time 1 has elapsed).

Error messages

DALI device failure

The 1-bit object "[Channel], DALI device failure" reports that the power supply to DALI devices must have failed. If more than the number configured with the parameter "Channel [A|B], failure >= DALI device(s)" are no longer responding to queries, a failure of the power supply for the DALI devices is assumed. If the object value = "0", then the power supply is present. If the object value = "1", then the power supply for the DALI devices has failed.

Power failure

The "Power failure" 1-bit status object reports the status of the common power supply for the gateway and the DALI line. If the object value = "0", then the power supply is present. If the object value = "1", then the power supply has failed. With this, the gateway is no longer functional and all ECG go to the configured dimming condition for a failure of the DALI voltage.

A short-term buffer power supply for the gateway electronics integrated with the device ensures that a mains power failure is detected and the power supply status telegram can still be transferred. These status objects are sent only if KNX communication is available.

DALI short circuit

The object "[Channel], DALI short circuit" reports a short circuit of the DALI line. If the object value = "0", then there is no short circuit. If the object value = "1", then the DALI line is short-circuited. The DALI gateway can no longer control the DALI devices and all ECG go to the dimming condition configured for a DALI voltage failure.

Groups

When controlling ECGs via groups, these objects are relevant for groups.

Switching on/off (1-bit)

ECGs connected to the gateway can be assigned to up to 32 groups.

A switching telegram to a group determines the configuration - whether the configured dimming value or the value before switching off is set. Whether the newly set value is dimmed or skipped is variable by means of a parameter. Switch-off telegrams always switch off. In timer mode, the delay time is (re)started if it has not been switched off. According to the configuration, switching telegrams enable delay times.

Dimming brighter/darker (4-bit)

The "Dimming time" property is variable. After receiving the start command, the gateway begins communication with the ECG to change the dimming value in the given direction with the configured speed. If a stop command is received before the dimming process has ended, the dimming process is interrupted and the dimming value reached is held. In timer mode, the delay time is (re)started if it has not been switched off. A parameter determines whether you can switch on and off via dimming.

Dimming value , 8-bit value (1 byte)

The communication object with the description "[Channel], [Group], Dimming value", sets all ECGs in this group to the transferred dimming value. Whether this value is skipped or dimmed is configurable. Depending on the configuration, say this object receives the value 0, the corresponding group is switched off. Values less than the minimum value (with the exception of the value 0) and values greater than the maximum value are limited to the minimum and maximum dimming values respectively. A parameter determines whether a switched off ECG assumes the received value immediately and switches on or assumes the received value only with an ON command. The configured switching value is then invalid. Depending on the configuration, dimming value telegrams also enable delay times. A communication object (3 bytes) can also control the group via a dimming value with a dimming time.

Dimming value limits

Limiting is used to configure maximum and minimum dimming values. With all switching/dimming processes, the dimming value can only be changed within the configured limits.

Switching status (1-bit)

The on/off status of any group can be sent via a communication object "[Channel], [Group], Switching status" on a read demand or automatically on an object value change.

KNX/DALI Gateway Twin N 141/31	5WG1141-1AB31
KNX/DALI Gateway Twin plus N 141/21	5WG1141-1AB21
KNX/DALI Gateway plus N 141/03	5WG1141-1AB03

Dimming value status (8-bit)

The object "[Channel], [Group], Dimming value status" is an 8-bit status object. It contains the current dimming value for the relevant group. It can be sent and/or read independently.

Error status (1-bit)

The 1-bit object "[Channel], [Group], Error status" can, for each group, report a detected lighting failure or ECG failure for a subscriber in this group, or also poll the status at any time.

Error status per channel (2-Byte)

The 2-byte status object "[Channel], Error status" can poll the error status of a group at any time. Depending on the configuration, error messages are sent for each ECG or only after polling has ended.

Scene control (8-bit)

The application program can configure up to 16 scenes per channel, each of which can contain up to 16 groups per channel. Scenes are saved and called up via the 8-bit object "8-bit scene, Recall/Save". The 3-byte "call up 8-bit scene with dimming time" object can also be used to call up a scene with a variable dimming time. Timer functions cannot be executed within a scene.

Replacement of defective ECGs without software

Defective ECGs can be replaced without software (ETS). Once the automatic device exchange is started, the gateway is able to test the DALI system for the completeness of the ECGs already activated.

If, for example, a defective ECG was removed by the installer and replaced by a new one, then the gateway is able to use the configuration data of the failed ECG to program the new ECG. This makes it possible to replace a failed ECG by simple operation on the device and without extensive configuration work in the ETS.

Preconditions:

- ECG must not have a short address (delivery condition or restored).
- Same device type.
- Minimum physical dimming value =< set minimum dimming value.
- Gateway commissioning fully completed.
- Bus and mains power connected to all ECGs.
- Gateway is in normal mode, direct mode or emergency mode

If more than one ECG is defective, then the individual ECGs can be replaced consecutively, whereby the correct

ECG number (not the short address) must be selected from the system documentation for each exchange. All other gateway functions are stopped during the device replacement process. The gateway subsequently executes all demands received following the replacement.

Care must be given to ensure that only one ECG is replaced in the described manner. If multiple ECGs have failed (possibly no mains voltage connected) and been replaced, the ECGs cannot be clearly identified and automatically configured by the gateway. This case requires a new start-up by the ETS plug-in.

KNX/DALI Gateway Twin N 141/31	5WG1141-1AB31
KNX/DALI Gateway Twin plus N 141/21	5WG1141-1AB21
KNX/DALI Gateway plus N 141/03	5WG1141-1AB03

Selectable functions

Productname	N 141/03 KNX/DALI Gateway plus		N 141/21 KNX/DALI Gateway Twin plus		N 141/31 KNX/DALI Gateway Twin	
	MLFB	5WG1 141-1AB03		5WG1 141-1AB21		5WG1 141-1AB31
Application number	983706	983711	983406	983411	983D06	983D11
Firmware Version	V06	V11/V12	V06	V11/V12	V06	V11/V12

DALI Channels	1		2		2	
ECG individual control	x	x	x	x	x	x
DALI sensors	x	x	x	x		
Emergency mode	x	x	x	x	x	x
Record of the emergency lights tests	x	x	x	x		
Constant lighting control	x	x	x	x		
2-point-lighting control	x	x	x	x		
Stand-by	x	x	x	x	x	x
Timer	x	x	x	x		
Effect control	x	x	x	x		
Scenes	16		16 per channel		16 per channel	
Burn-in function (complete system)	x	x	x	x		
Burn-in function via object	x	x	x	x	x	x
Pre-loaded applications	x	x	x	x		
Color temperature control		x		x		x

Table 1 Functions overview by KNX/DALI Gateway and application program

KNX/DALI Gateway Twin N 141/31	5WG1141-1AB31
KNX/DALI Gateway Twin plus N 141/21	5WG1141-1AB21
KNX/DALI Gateway plus N 141/03	5WG1141-1AB03

Sensors

The gateway supports selected sensors, such as key interfaces, presence detectors and brightness sensors with a DALI interface. Sensors are powered by the gateway. Sensors are powered by the gateway. Sensors can be connected individually with other objects via the objects and are therefore independent.

The following DALI ed.1 sensors are supported (currently only Siemens and OSRAM):

DALI push button input (maximum 16 per channel)

Description	Order no.	Manufacturer
DALI 4x button input	5WG1 141-2AB71	Siemens
DALI PRO PB coupler	4008321496461	OSRAM

DALI presence detector (maximum 8 per channel)

Description	Order no.	Manufacturer
DALI LS/PD LI sensor coupler *	4052899043954	OSRAM
DALI LS/PD CI *	4052899930292	OSRAM
DALI sensor coupler E *	4052899230491	OSRAM
DALI sensor LS/PD DALI LI UF *	4052899984608	OSRAM
DALI sensor coupler HF *	4052899141728	OSRAM
DALI HF LS LI sensor *	4052899921481	OSRAM
DALI HIGH BAY Adapter	4008321774132	OSRAM
Sensors for HIGH BAY Adapter		
High-Bay PIR	4008321410078	OSRAM
Vision	4008321957047	OSRAM
DALI PRO sensor coupler	4008321379269	OSRAM
Sensors for DALI sensor coupler		
Sensor Multi3 LS/PD for luminaire installation	4050300802138	OSRAM
Sensor Multi3 LS/PD FL for luminaire inst.	4050300047342	OSRAM
Sensor Multi3 LS/PD B for luminaire inst.	4050300803081	OSRAM
Sensor Multi3 LS/PD A for luminaire inst.	4008321653604	OSRAM
Sensor Multi3 LS/PD for ceiling installation	4008321916648	OSRAM
DALI Presence detector (6 mA) *)	-	Compatible to Siemens specification (Currently only OSRAM)

* not possible with pre-loaded applications

The following DALI-2 sensors are supported** (Currently only OSRAM):

DALI-2 presence detector (maximum 8 per channel)

Description	Order no.	Manufacturer
DALI COUPLER MULTI3 G2 25X1 *	4062172072113	OSRAM
DALI SENSOR LS/PD LI G2 25X1 *	4062172072069	OSRAM
DALI SENSOR LS/PD CI G2 10X1 *	4062172072083	OSRAM
D DALI COUPLER HF G2 25X1 *	4062172072199	OSRAM
DALI COUPLER E G2 25X1 *	4062172072212	OSRAM
DALI COUPLER LS HIGH-BAY G2 20X1 *	4062172072137	OSRAM
DALI SENSOR LS/PD LI UF G2 10X1 *	4062172072045	OSRAM

* not possible with pre-loaded applications

** these sensors can only be commissioned as "DALI Presence detector" (6 mA)

The amount of sensors is limited to the current consumption of the sensors and can be less than the maximum.

In case of „DALI Presence detector (6 mA)“ the use of a compatible DALI device to Siemens specification is expected with a current consumption of 6 mA. The functionality cannot be guaranteed, because there is no check of the GTIN (order no.) on the DALI device.

ECG

ECGs can be controlled individually without group assignment. The functions are to be seen as being similar to the group control functions as described in groups.

2-point control

Up to sixteen independent switching brightness controllers (2-point controllers) are provided. These are independent of all other functions and can be used via objects.

Constant lighting control

Up to 16 independent constantly operating lighting controllers are provided. These are independent of all other functions and can be connected and used both internally and externally via objects.

KNX/DALI Gateway Twin N 141/31	5WG1141-1AB31
KNX/DALI Gateway Twin plus N 141/21	5WG1141-1AB21
KNX/DALI Gateway plus N 141/03	5WG1141-1AB03

Stand-by

This function makes it possible to define up to 12 areas, for which the ECG power supply is shut off by a separate load switch when all of the ECGs in this area have a brightness value of zero (0). This serves to reduce the quiescent power consumption of the ECGs.

Timer

This function makes it possible to define up to 10 channels which can be assigned to up to 2000 switching times. The switching times can be defined as daily/weekly or date schedules and as absolute time or relative to the sunrise/sunset.

Effect control (Sequencer)

Up to 1000 steps can be defined in up to 4 effects. Every step can be assigned to one of 20 effects channels. Every effects channel has a communication object. The effects can run in parallel and use an object to display the current status.

Burn-in function (Complete system)

The burn-in function for the complete system makes it possible to have all of the ECGs switched on to 100% following a defined time period (Standard = 100 hrs) after the initial start-up of the system. The control buttons on the device can be used to start the burn-in operation.

The standard value can be configured in the ETS. Upon completion of the burn-in operation, the device switches automatically to normal mode (bus mode) or to stand-alone mode depending on the configuration. All of the ECGs are shut off. The time remaining is saved if a power loss occurs during the burn-in operation. The burn-in operation continues for the time remaining after the power is restored.

Burn-in function via object

The function is similar to constant light. The controlled value is the maximum configured dimming value. The ECG or group can no longer be controlled by the objects. An ongoing time function is interrupted. Errors continue to be reported. The status displays the maximum dimming value.

The "behavior following burn-in" can be defined in the configuration for groups or ECGs. After the burn-in process is deactivated, the ECG or group is set to the value defined by the "Value at the end of the burn-in function" parameter.

During the burn-in process, commands on scenes containing an ECG or a group are discarded.

If the "Value at the end of the burn-in function" parameter is set to "No burn-in possible", then the burn-in process cannot be started for this ECG.

The burn-in function is deactivated and the „Value at the end of the burn-in function" parameter is set to "No burn-in possible" for an ECG with activated brightness control. The status of the burn-in function is saved when a power loss occurs.

Emergency mode

The gateway supports both emergency lighting systems with a central battery supply and emergency lights with an individual battery supply as per IEC62386-202 with one or two DALI devices.

In the case of central battery supply, the "Dimming value in emergency mode" can be defined within the ECG parameter settings. In the case of DALI failure, this is transferred to the ECG as "system failure level" dimming value. If emergency mode is activated, the "system failure level" is sent by the object to the ECG as the current dimming value.

Emergency lights test results

It is possible to perform cyclical function tests in accordance with the legal requirements when emergency light ECGs are used with individual battery supplies. The test results can be forwarded by an object either to a documentation system or to an internal memory. The internal memory can be read out with the ETS Plug-in and backed up in a file.

The data are written over on a rolling basis when the memory overflows, with the upcoming memory overflow being reported by an object and by the screen info-display.

Blocking battery mode for emergency lights

Emergency lighting ECGs with batteries convert automatically to their individual battery supply when a general power failure occurs. It is necessary in special cases, e.g. during the construction phase, to switch off the power supply to the emergency lights operated by individual batteries without these lights converting to emergency mode.

The gateway inserts a locking indicator in the emergency light ECG when this mode (inhibit) is activated in accordance with the following description.

The setting of the locking indicator is signaled by a brief flashing of the emergency lighting LED.

KNX/DALI Gateway Twin N 141/31	5WG1141-1AB31
KNX/DALI Gateway Twin plus N 141/21	5WG1141-1AB21
KNX/DALI Gateway plus N 141/03	5WG1141-1AB03

If the power is shut off, e.g. by tripping the miniature circuit breaker, within 15 minutes after setting the locking indicator, then this does not go into emergency mode and thus remains disabled until the power is restored. After the power is restored, the emergency light ECG goes into standard mode and the locking indicator is deleted.

Suppress error messages

ECG is disconnected from DALI in connection with the emergency lighting test. The gateway evaluates this disconnection as an ECG error and thus also sends error telegrams via KNX. The sending of error messages can be blocked to prevent this unnecessary information.

Emergency mode configuration

The "Emergency mode" object can be used to dim all lights not controlled by a DALI- gateway to the configured "Dimming value in emergency mode" in order to dim all of the lights to the same brightness value as the battery-operated emergency lights when a mains failure or communication failure occurs via the DALI- cable. The following actions are taken at the start of emergency mode:

- The dimming values for emergency mode are set.
- An actively running effect is stopped.
- The constant lighting controls are stopped.
- All of the time functions are stopped.
- The execution of timer commands is interrupted.

The following restrictions result during emergency mode:

- None of the lights react to switching and dimming commands while "emergency mode" is activated.
- No effects can be started or scenes called up.
- The constant lighting control cannot be started.
- The execution of timer actions is stopped.
- No commissioning can be carried out.

The following actions are taken under this priority at the end of the emergency mode.

- Commands for switching, dimming values and scenes are updated, but not relative dimming.
- Setting of the dimming values according to the parameter setting if no other values were received.
- Restart of the time functions, if the ECG / Group is on.
- Constant light control is restarted in accordance with the parameter setting.
- Time functions are updated in accordance with the parameter setting.

Pre-loaded Applications

The gateway supports a series of standard applications for pure DALI operation without KNX. These can be activated without software (ETS) by using the control buttons. These standard applications exclusively use broadcast to control the DALI channels and incorporate DALI-enabled sensors into the application.

The following applications are provided:

- A0 - Base function
- A1 – Manual mode A
- A2 – Manual mode B
- A3 - manual mode with delay time
- A4 – manual mode with delay time, 2-stage
- A5 - Off, depending on presence
- A6 - depending on presence
- A7 - presence-dependent Off, 2-stage
- A8 - Semiautomatic constant light control
- A9 - Fully automatic constant light controller

(see application description - APB for additional information)

Color temperature control

The color temperature control is defined in standard DALI IEC 62386, in chapter 209 "Color Control." The ECG is defined as device type 8. Device type 8 refers to color controllable lights. The unit for color temperature is Kelvin (K).

Das Gateway can control the color temperature and brightness of ECG of device type 8.

The device can be used in human-centric lighting (HCL) application. As the color temperature is adjustable in scenes, effects and in the scheduler, the KNX/DALI GW can be used in HCL applications without the need for external KNX devices.

Human-centric lighting (HCL) expands the concept of biologically effective lighting with holistic planning and covers the visual, emotional and biological effects of light. HCL supports human health, well-being and performance in the long-term.

KNX/DALI Gateway Twin N 141/31
 KNX/DALI Gateway Twin plus N 141/21
 KNX/DALI Gateway plus N 141/03

5WG1141-1AB31
 5WG1141-1AB21
 5WG1141-1AB03

Technical Data

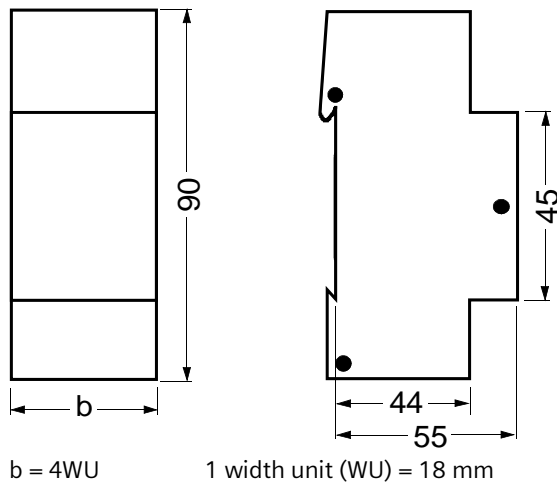

Fig. 4 Dimensions in mm

Power supply

- KNX bus voltage: carried out via the bus line
- KNX bus current: 5 mA
- Electronics and DALI interface:
 - Integrated power supply for
 - AC 110-240 V, 50-60 Hz
 - DC 120-240V
- - Power consumption: max. 11 W (N 141/31 -/21)
 max. 6W (N 141/03)

Inputs/outputs

- Mains connection: 3-pole (↓, N, L)
- DALI interface with DALI-2 certification according to IEC 62386-101 and 103:
 - DALI Single-Master Application Controller
 - max. 64 DALI devices per channel (each max. 2 mA) with > 8 kOhm input impedance
 - max. amount of sensors per channel depends on the current consumption of the sensors (type 10 with 6mA each)
 - DALI power supply per channel:
 - approx. DC 19 V, floating, short-circuit-proof
 - max. current: $I_{max} = 250$ mA
 - max. guaranteed current: $I_{nmax} = 190$ mA
 - Shutdown mechanism:
 - Shutdown delay time 700 ms
 - Restart period 10 s

- DALI cable length for cooper at 25°C:
 - 2.5 mm² max. 300 m
 - 1.5 mm² max. 300 m
 - 1.0 mm² max. 224 m
 - 0.75 mm² max. 168 m
 - 0.5 mm² max. 112 m
- Loop resistance max 10 Ohm

Operating elements

- 1 teach-in button:
 - toggle normal mode / addressing mode
- 2 buttons:
 - toggle between bus- / direct mode; edit menu
- 4 buttons:
 - all ECG on / off and dimming;

Display elements

- Device info display, 7 segment display, 2-digit, amber
- 2 LED red
- LED addressing mode

Connections

- Conductors for net power supply and DALI terminal, stripping length 10 ... 11 mm (see stamping)
- The following conductor cross-sections are permitted:
 - 0.5 ... 2.5 mm² single-core
 - 0.5 ... 2.5 mm² multi-core
 - 0.5 ... 2.5 mm² finely stranded, untreated
 - AWG 20 (0.75 mm²) – AWG 12 (3.3 mm²) solid, stranded
- The supply cable to the device must be fused with a circuit-breaker of characteristic B or C for a max. nominal current of 6 A!
- KNX bus: bus terminal

Mechanical data

- Dimensions: device for DIN rail mounting in N-system dimensions, width: 4WU (1WU = 18 mm)
- Weight: approx. 180 g
- Fire resistance: approx. 4 MJ ± 10%

Electrical safety

- Protection type (according to IEC 60529): IP 20

Reliability

- Failure rate: 419 FIT at 40°C

KNX/DALI Gateway Twin N 141/31	5WG1141-1AB31
KNX/DALI Gateway Twin plus N 141/21	5WG1141-1AB21
KNX/DALI Gateway plus N 141/03	5WG1141-1AB03

Environmental specifications

- Climatic withstand capability: EN 50491-2
- Ambient operating temperature: - 5 ... + 45 °C
- Storage temperature: - 25 ... + 70 °C
- Relative humidity (not condensing): 5 % to 93 %

Markings

- KNX EIB

Installation instructions

- The device may be used for permanent interior installations in dry locations within distribution boards or small casings.



DANGER

- The device must be mounted and commissioned by an authorized electrician.
- A safety disconnection of the device must be possible.
- The device must not be opened.
- For planning and construction of electric installations, the relevant guidelines, regulations and standards of the respective country are to be considered.

Location and Function of the Display and Operating Elements

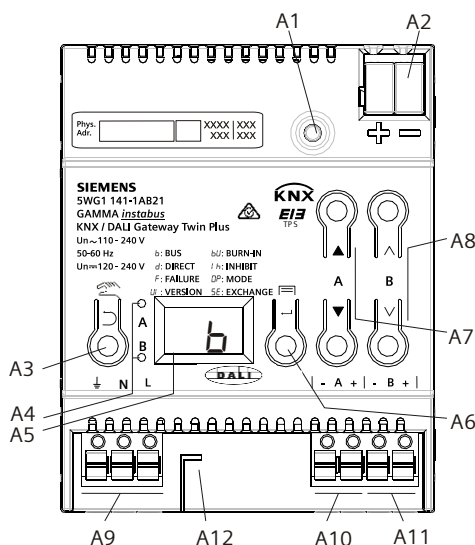

- A1 Programming button with LED (red)
Programming mode: Briefly pressing and releasing the programming button (< 0.5 s) activates the programming mode. This is displayed by flashing of the programming LED.
Factory settings: Pressing and holding down the programming button for a prolonged time period (> 20 s) restores the device to its factory settings. This is displayed by uniform flashing of the programming LED. The flashing stops after 5 s.
Note: No functions are executed when the programming button is held down for a longer period of time (> 0,5 s to 2 s). The device can be blocked for programming mode for approx. 10 s. This is displayed by brief flashing of the programming LED.
- A2 Plug for KNX terminal
- A3 Button when pressed
Briefly: "back" ↶
Held down: Direct mode ↷
- A4 Both these LEDs display information about the relevant channel.
- A5 Device info display
- A6 Button when pressed
"OK" ← or Menu ≡
- A7 Button pair ▲ ▼ for menu control or direct operation of channel A
- A8 Button pair ^ v for submenu control or direction operation of channel B
- A9 Terminals for ground, neutral and phase lines (⊥, N, L)
- A10 Terminal pair for DALI channel A
- A11 Terminal pair for DALI channel B
- A12 Stripping template (stamping)

KNX/DALI Gateway Twin N 141/31	5WG1141-1AB31
KNX/DALI Gateway Twin plus N 141/21	5WG1141-1AB21
KNX/DALI Gateway plus N 141/03	5WG1141-1AB03

Mounting and wiring

The device may be used for permanent interior installations in dry locations within distribution boards or small casings with DIN rail EN 60715-TH35-7,5.

Mounting and dismounting the device:

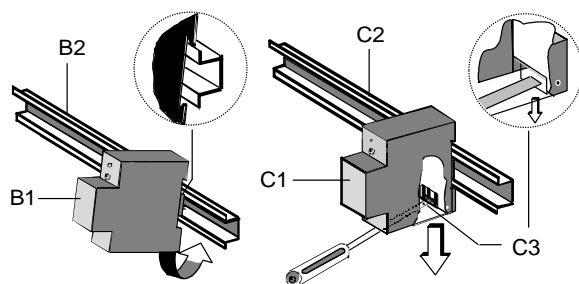

Connecting and disconnecting the bus cable:

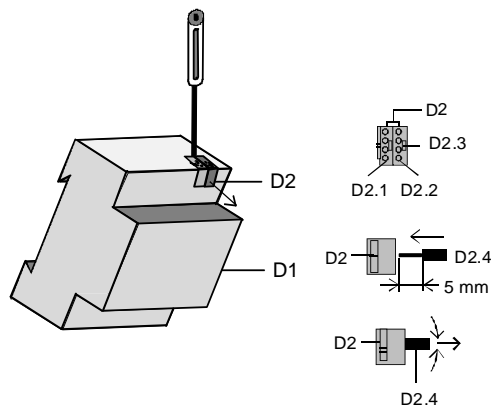

Incorrect voltage detection

The device is fitted with a voltage detector on both DALI channels. If an incorrect voltage is detected during initialization because lines have been connected to terminals A10 and A11 incorrectly, the device info indicator flashes with the symbol . This protects the device against excessive voltage, e.g. if 24V or 230 V AC (N, L) is applied to the pair of terminals A10 and A11. This mode is maintained until the connection error is corrected.

NOTE:

Owing to the internal connection of DALI terminals channel A- and channel B-, an incorrect voltage present here will not be detected and this will cause a direct short circuit and damage to the device.

KNX/DALI Gateway Twin N 141/31	5WG1141-1AB31
KNX/DALI Gateway Twin plus N 141/21	5WG1141-1AB21
KNX/DALI Gateway plus N 141/03	5WG1141-1AB03

General Notes

- The operating instructions must be handed over to the client.
- Any faulty device is to be sent together with a return delivery note of the local Siemens office.

- If you have further questions concerning the product please contact our technical support:

 +49 (911) 895-7222

 +49 (911) 895-7223

 support.automation@siemens.com

www.siemens.com/automation/support-request