

ACVATIX™

Rotary actuators for 6-port ball valves

GDB161.9../.6..



Electromotoric rotary actuators for modulating or Modbus control. Used in heating, ventilation and air conditioning plants.

- Nominal torque 5 Nm
- For VWG41.. series 6-port control ball valves
 - GDB161.9../6W
 - GDB161.9E/MO6P
- For VWPG51.. series 6-port pressure independent control ball valves (PICVs)
 - GDB161.9../6W (when manual pre-setting is not desired)
 - GDB161.9../6P
 - GDB161.9E/MO6P
- Specific firmware for 6-port application
- Pre-setting of cooling and heating max. flows through manual operation with screws:
 - GDB161.9../6P
- Pre-wired with 0.9 m, 3 m or 5 m long connection cables

Features

- Brushless, robust DC motors ensure reliable operation regardless of load.
- The rotary actuators do not require an end position switch, are overload proof, and remain in place upon reaching the end stop.
- The gears are maintenance free and low noise.
- Suitable for use with modulating controllers (DC 0/2...10 V) and Modbus RTU controllers.

Functions

Type	AC 24 V ~ / DC 24...48 V =	GDB161.9../6W	GDB161.9../6P	—
	AC 24 V ~ / DC 24 V =	—	—	GDB161.9E/MO6P
Control type	Modulating control (0/2...10 V)			Modbus RTU
Rotary direction	Clockwise (CW) or counter-clockwise (CCW) direction depends on: <ul style="list-style-type: none"> • the setting of the rotary direction DIP switch <div style="display: flex; justify-content: space-around; align-items: center;"> <div style="text-align: center;"> <p>CW</p> </div> <div style="text-align: center;"> <p>CCW</p> </div> </div> <ul style="list-style-type: none"> • the positioning signal <p>The actuator remains in the achieved position if:</p> <ul style="list-style-type: none"> • ... the control signal is maintained at a constant value. • ... the operating voltage is lost. 			Configurable through Modbus registers Refer to "Modbus registers"
Combination with 6-port control ball valves	Rotary direction "counter-clockwise" (CCW)			Configurable through Modbus registers Refer to "Modbus registers"
	Y = 0 (2) V	Flow A – C = 100 % (0°)		
	Y = 10 V	Flow B – C = 100 % (90°)		
	Rotary direction "clockwise" (CW)			Configurable through Modbus registers Refer to "Modbus registers"
Y = 0 (2) V	Flow B – C = 100 % (0°)			
Y = 10 V	Flow A – C = 100 % (90°)			
Position indication	Mechanical	Rotary angle position indication by a position indicator/hand lever.		
	Electrical	Output voltage U = DC 0/2...10 V is generated proportional to the rotary angle. U depends on the rotary direction of the DIP switch setting.		Actual value 0...100 % for valve position Refer to "Modbus registers"
Cooling and heating maximum flows presetting	Not available - VWG41.. series 6-port control ball valves are delivered with kvs disks.		Manual flow pre-setting with 2 screws on the actuator.	Configurable through Modbus registers Refer to "Modbus registers"
Maximum flows and self-adaption	-		Total rotation angle is	Configurable through Modbus

Type	AC 24 V ~ / DC 24...48 V =	GDB161.9../6W	GDB161.9../6P	—
	AC 24 V ~ / DC 24 V =	—	—	GDB161.9E/MO6P
			determined by the actuator through self-calibration triggered via DIP switch after manual pre-setting with screws. Dead band zone (no flow) is fixed and not influenced by the new adjusted positions.	registers Refer to "Modbus registers"
Manual override	A push button disengages the internal gears letting the actuator to be manually adjusted or overridden.			
Backup function	Actuator drives the valve to the closed position (45°) for open Y signal input (0 V) when 2...10 V control mode is selected.		Actuator drives the valve to a pre-defined backup position through Modbus registers. Refer "Parameterization"	
Modbus RTU (RS-485), not galvanically isolated	-	-	Setpoint 0...100 % valve position Actual value 0...100 % for valve position Override control Setpoint monitoring and backup mode	

Technical design

Housing

The housing is made of fiberglass reinforced plastic:

- Flame retardant
- Non-brominated
- Non-chlorinated

Type summary

Type	Stock no.	Positioning signal	Operating voltage	Position indicator	Rotation direction switch	Cable length
GDB161.9E/6W	S55499-D784	Modulating	AC 24 V ~ / DC 24...48 V =	U = DC 0...10 V =	DIP switch	0.9 m
GDB161.9E/6P	S55499-D801					
GDB161.9E/MO6P	S55499-D802	Modbus RTU	AC 24 V ~ / DC 24 V =	Modbus register 0...100 %	Modbus register	
GDB161.9G/6W	S55499-D829	Modulating	AC 24 V ~ / DC 24...48 V =	U = DC 0...10 V =	DIP switch	3 m
GDB161.9G/6P	S55499-D827					
GDB161.9H/6W	S55499-D830					
GDB161.9H/6P	S55499-D828					5 m

Spare parts

Individual spare parts are not available. Components of the accessory kit ASK77.3 ¹⁾ can however be used for spare parts.

Description	Components
ASK77.3 Mounting kit BV for GxBxx1.9E	Mounting bracket (base plate) Axle with sleeve and spring Manual lever with locking clip

¹⁾ Can also be used as rotary actuator for ball valves together with the actuator for air dampers G..B.1E.

Equipment combinations

GDB161.9../6W, GDB161.9E/MO6P and VWG41.. series 6-port control ball valves PN16

Medium: 5...90 °C	Connection	Flow [m ³ /h]	DN	Δp_{max} [kPa] ¹⁾
VWG41.10..	G ½ " B	0.25...1.9	10	200
VWG41.20..	G 1 " B	0.25...4.25	20	

GDB161.9../6W, GDB161.9../6P, GDB161.9E/MO6P and VWPG51.. series 6-port pressure independent control ball valves PN25

Medium: 5...90 °C	Connection	Flow [m ³ /h]	DN	Δp_{max} [kPa] ¹⁾
VWPG51.15..	G ¾ " B	35...1200	15	400
VWPG51.20..	G 1 " B	460...4250	20	

¹⁾ Δp_{max} = Maximum permissible differential pressure over the ball valve control path, valid for the entire positioning range of the ball valve rotary actuator unit

Product documentation

Topic	Title	Document ID
Data sheet: Technical information	6-port control ball valve VWG41..	A6V10564480
Data sheet: Technical information	6-port pressure independent control ball valve (PICV) VWPG51..	A6V12815016
Mounting	Mounting instructions 6-port control ball valve VWG41..	A6V10564501
Mounting	Mounting instructions 6-port pressure independent control ball valve (PICV) VWPG51..	A6V12814982
Mounting	Mounting instructions rotary-type actuator GDB161.9E/..6..	A6V12815008

Related documents such as the environmental declarations, declarations of conformity, etc., can be downloaded from the following Internet address:

www.siemens.com/bt/download

Safety

 **CAUTION**
**National safety regulations**

Failure to comply with national safety regulations may result in personal injury and property damage.

- Observe national provisions and comply with the appropriate safety regulations.

Engineering

GDB161.9../.6.. actuators are recommended for use at medium temperatures $> 0\text{ }^{\circ}\text{C}$.

If the medium temperature is $\leq 0\text{ }^{\circ}\text{C}$, the adapter shaft must be greased with silicon grease.

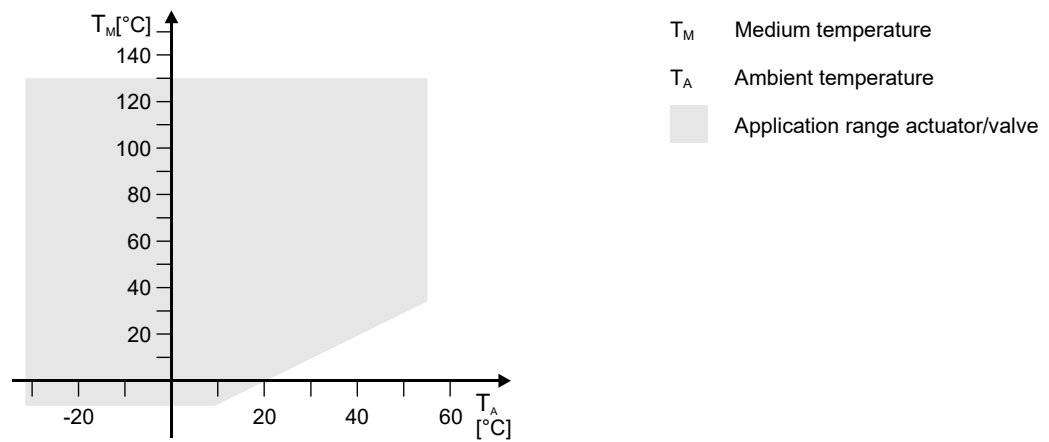
**GDB161.9E/MO6P**

The Modbus converter is designed for analog control at 0...10 V.

Mounting

Both ball valve and rotary actuator can be easily and directly assembled at the mounting location. No special tools or adjustments required.

Alignment

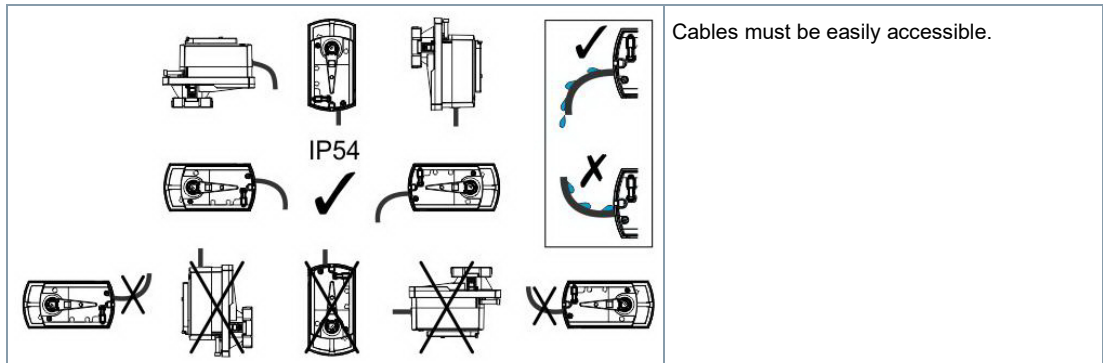

Protection against weather, humidity and dirt

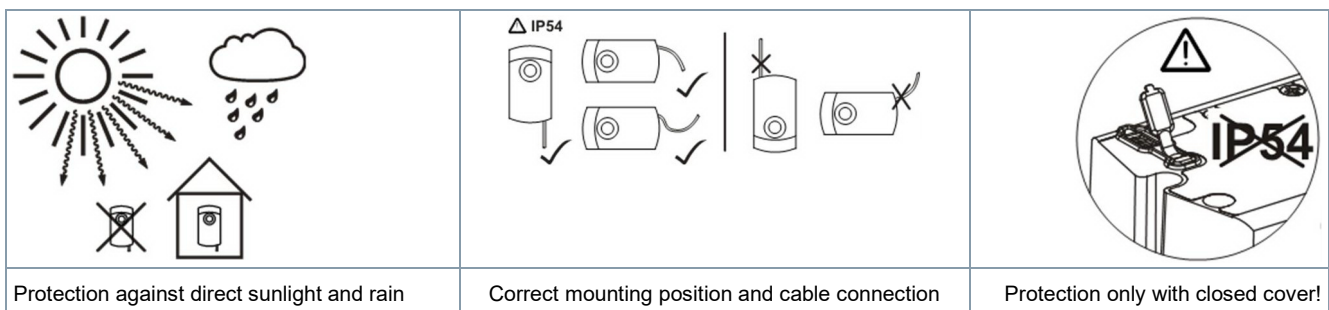

Installation

⚠ WARNING	
	<p>No internal line protection for supply lines to external consumers</p> <p>Risk of fire and injury due to short-circuits</p> <ul style="list-style-type: none"> Adapt the line diameters as per local regulations to the rated value of the installed fuse.

Commissioning

When commissioning the system, check wiring and the functions of the rotary actuator.

Manual adjustment

The rotary actuator can be manually adjusted into any position between 0° and 90° by pushing the gear train disengagement slider.

If a control signal from the controller is present, this will take priority in determining the position after the slider is released.

For manual adjustment: Power off!

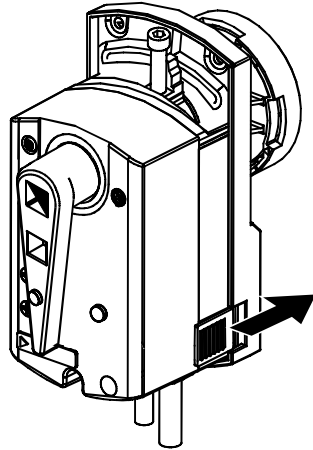

Maintenance

The actuators GDB161.9../.6.. are maintenance-free.

Disposal



The device is considered an electronic device for disposal in accordance with European guidelines and may not be disposed of as domestic waste.

- Dispose of the device through channels provided for this purpose.
- Comply with all local and currently applicable laws and regulations.

Warranty

Technical data on specific applications are valid only together with Siemens products listed under "Equipment combinations". Siemens rejects any and all warranties in the event that third-party products are used.

Parameterization

The following operating mode is available for the GDB161.9E/MO6P model:

- 6WV operation mode: The actuator uses two separate setpoints for heating and cooling, each with a range of 0...100 %.

The GDB161.9../6P and GDB161.9../6W models have a specific 6-port firmware for the VWPG51.. and VWG41.. series respectively.

Operating mode "6WV" for GDB161.9E/MO6P

When using the 6WV operation mode, the parameters for these valve series can be selected:

- VWG41.. series 6-port control ball valves DN10 and DN20
- VWPG51.. series 6-port pressure independent control ball valves (PICV) DN15 and DN20

Details on the characteristic curves of these two valves can be found in the datasheets A6V10564480 (VWG41..) and A6V12815016 (VWPG51..).

Note that both the valve angle [°] and the default actuator rotation direction are counter-clockwise (CCW). Therefore, a valve angle of 90° is achieved by an actuator position of 100 % etc.

One of the two setpoints (heating or cooling) needs to be "0 %" for the actuator to be able to move. If neither setpoint is "0 %", the actuator does not move until the setpoint conflict is resolved.

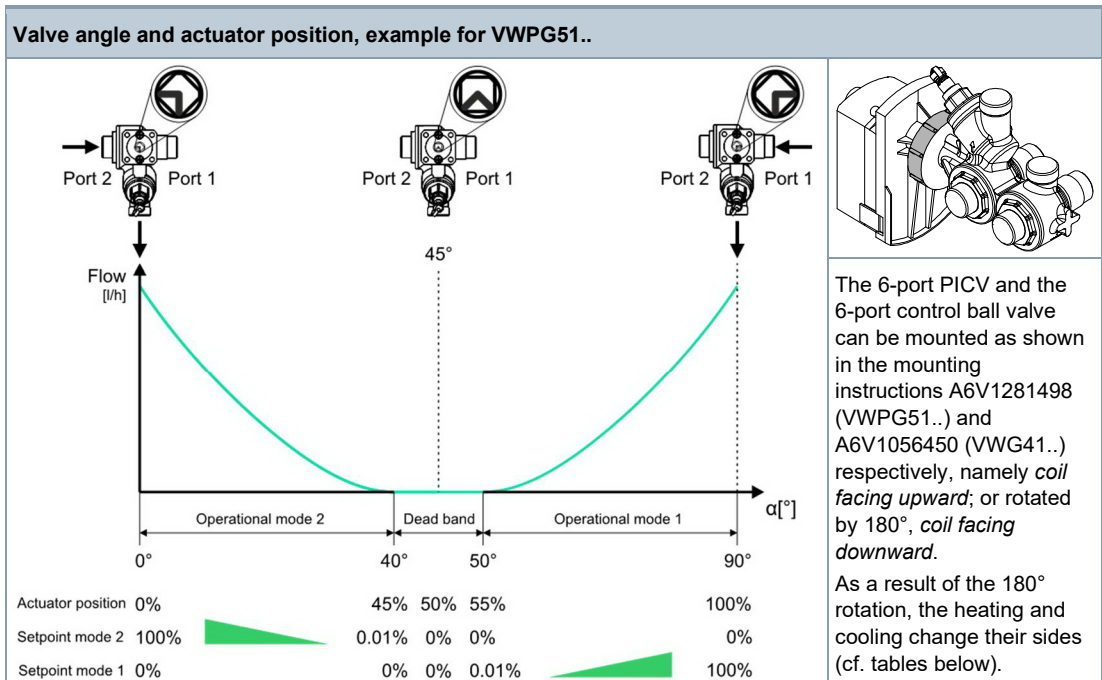

Parameters for standard piping of heating and cooling (GDB161.9../.6.. rotation direction: CCW, Reg. 257 =1):

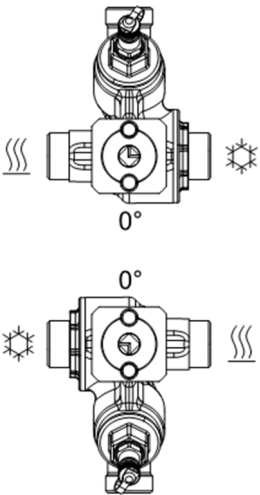
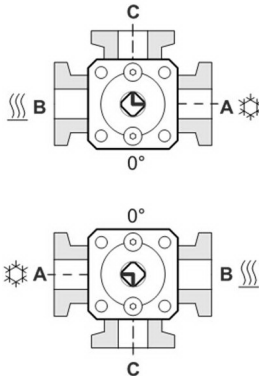
Parameter	VWPG51..			VWG41.10		VWG41.20		
	Valve angle	Actuator position		Valve angle	Actuator position	Valve angle	Actuator position	
MaxPositionHeating	90°	100 %	0°	75°	84 %	75°	84 %	
MinPositionHeating	50°	57 %	0°	60°	67 %	50°	55 %	
ClosedPosition	45°	50 %	0°	45°	50 %	45°	50 %	
MinPositionCooling	40°	43 %	0°	30°	33 %	40°	45 %	
MaxPositionCooling	0°	0 %	0°	15°	16 %	15°	16 %	

By rotary direction parameter inversion (CW, Reg. 257 = 0), heating and cooling are swapped:

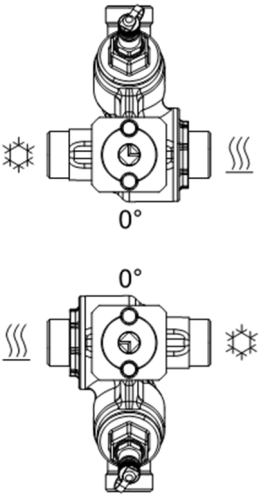
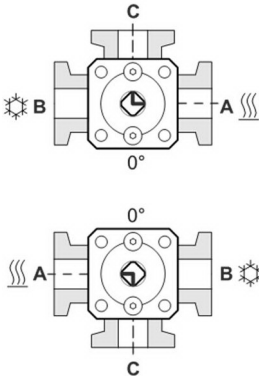
Parameter	VWPG51..			VWG41.10		VWG41.20		
	Valve angle	Actuator position		Valve angle	Actuator position	Valve angle	Actuator position	
MaxPositionHeating	0°	100 %	0°	15°	84 %	15°	84 %	
MinPositionHeating	40°	57 %	0°	30°	67 %	40°	55 %	
ClosedPosition	45°	50 %	0°	45°	50 %	45°	50 %	
MinPositionCooling	50°	43 %	0°	60°	33 %	50°	45 %	
MaxPositionCooling	90°	0 %	0°	75°	16 %	75°	16 %	

Operating mode for GDB161.9../6P and GDB161.9../6W

The following analogue control types are available for the GDB161.9../6P and GDB161.9../6W models:

- 0...10 V control
- 2...10 V control: includes a backup function with the actuator driving the valve to the closed position (45°) for open Y signal input (0 V)

Note that both the valve angle [°] and the default actuator rotation direction are counter-clockwise (CCW). Therefore, valve angle 90° is achieved by a control signal to the actuator of 10 V etc.

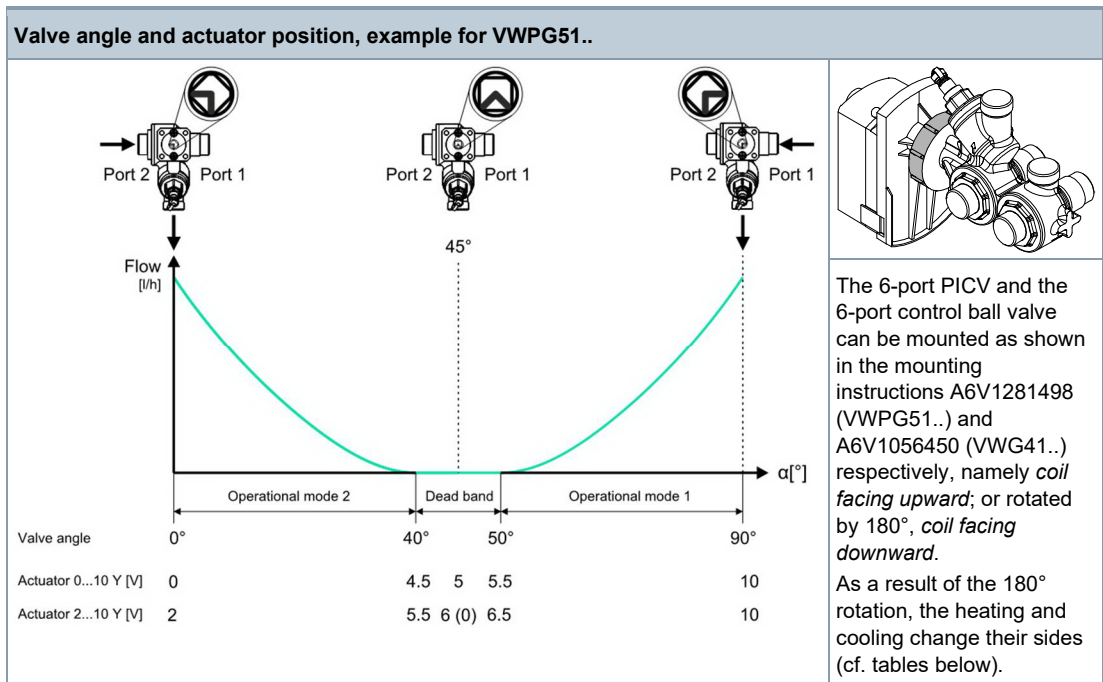

Cooling and heating allocation is freely selectable. However, Siemens suggests an equal allocation for all valves during installation for safety reasons, as shown below:

- Operational mode 2 (ports 2-4) = cooling
- Operational mode 1 (ports 1-3) = heating

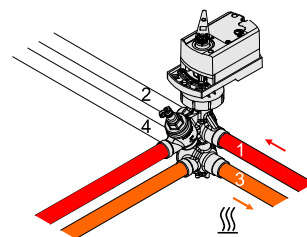
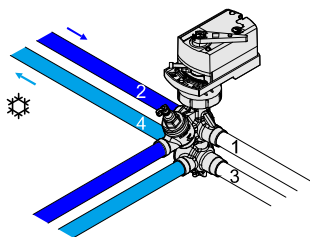

Where:

- Max. position heating corresponds to 100% actuator position (GDB161.9E/MO6P)
- Max. position heating corresponds to 10 V (GDB161.9../6P and GDB161.9../6W)

CCW is considered the default rotation direction for the GDB161.9../.6.. series actuators.

By changing the rotation direction to CW, the heating and cooling sides are swapped and the conditions below come into play:

- Operational mode 2 (ports 2-4) = heating
- Operational mode 1 (ports 1-3) = cooling

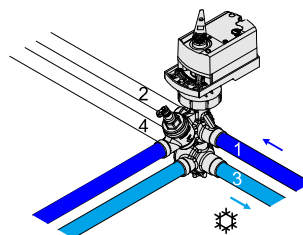
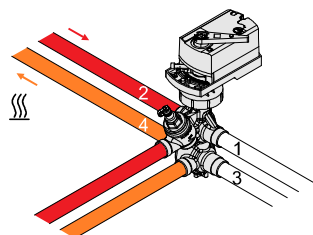

Pre-setting

For the GDB161.9../6P modulating actuators, the maximum flow for cooling and heating for the VWPG51.. series 6-port pressure independent control ball valves can be set by:

- Manual pre-setting with screws on the actuator
- Voltage signal limitation to the actuator at controller or thermostat level

For the GDB161.9../6W modulating actuators, the maximum flow for cooling and heating for the VWPG51.. series 6-port pressure independent control ball valves can be set by:

- Voltage signal limitation to the actuator at controller or thermostat level

For the GDB161.9E/MO6P Modbus actuator, the maximum flow for cooling and heating for the VWPG51... series 6-port pressure independent control ball valves can be set via the following Modbus registers:

Address	Register	Name	Read/Write	Range/Listing	Factory setting
259	260	Max. Limit Heating	RW	0...100 % = 0...10000	100 %
260	261	Max. Limit Cooling	RW	0...100 % = 0...10000	100 %

Manual pre-setting

Maximum flow for cooling and heating can be manually pre-set using the screws on the GDB161.9../6P actuators, limiting the rotation angle:

- a) Set the screws to the desired position to meet application maximum flow for cooling and heating based on the flow presetting tables in the data sheet A6V12815016 for the VWPG51.. series valves.

Refer to the mounting instructions A6V12815008 for the GDB161.9../.6.. series actuators.

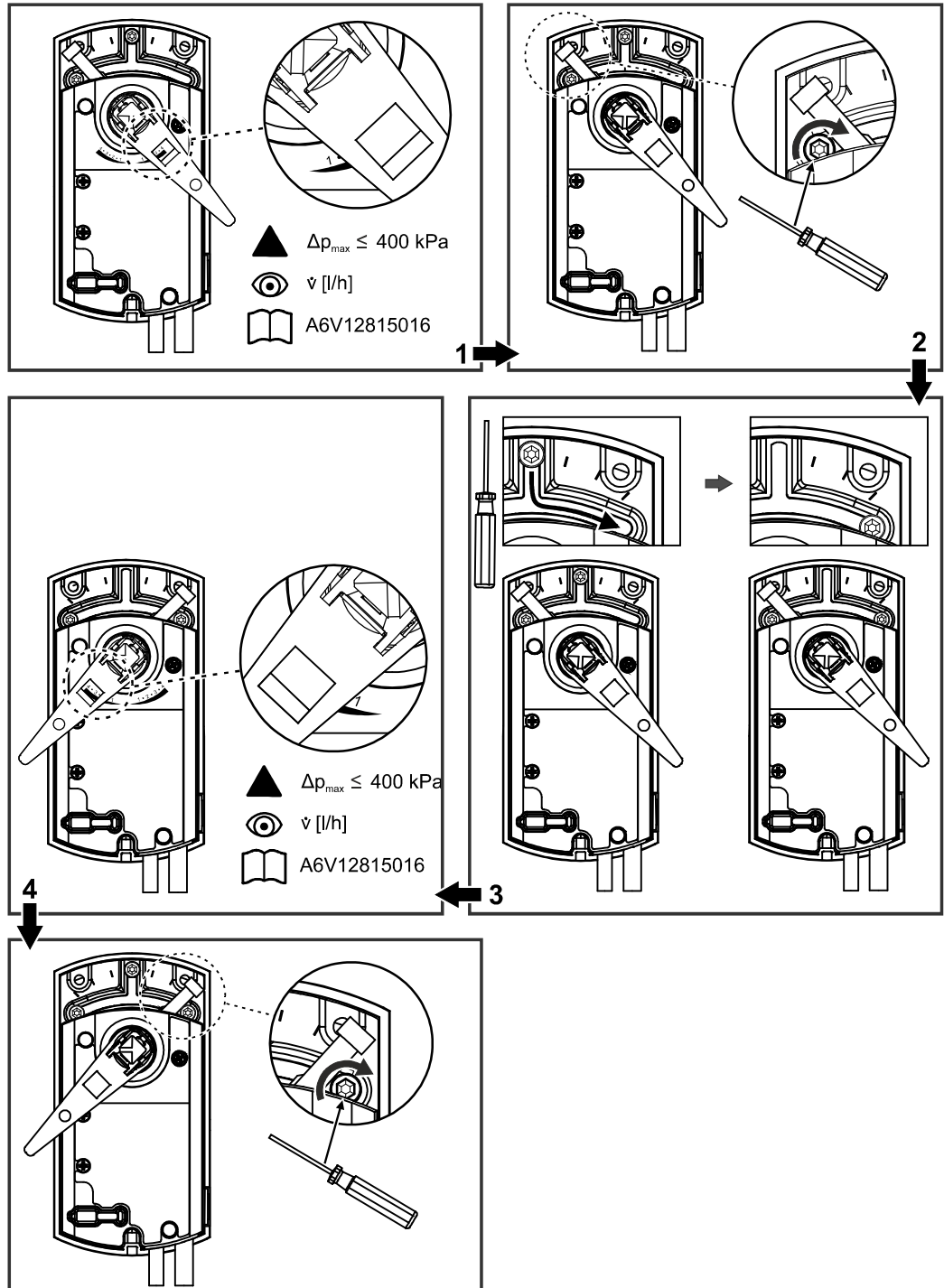

- b) Power on the actuator.

c) Flip the DIP switch to activate self-calibration.

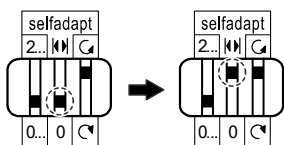

- ⇒ The screw positions are automatically found via self-calibration.
- ⇒ The actuator recognizes the new rotation angle and splits the 0/2...10 V control signal range through it.
- ⇒ The dead band area (45°) is fixed and not influenced by the new adjusted positions.

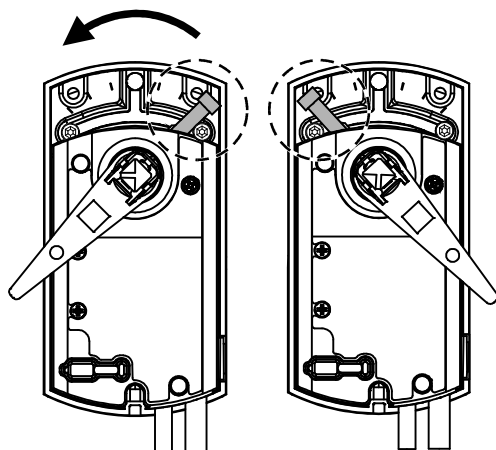

Voltage signal limitation pre-setting

Maximum flow for cooling and heating can be pre-set at the controller or thermostat level using voltage signal limitation to the actuator.

By limiting the voltage signal to the actuator, the rotation angle is limited as well, therefore reducing the maximum cooling and heating flows delivered by the valve.

The desired voltage signal limitation can be found in the flow presetting tables in the datasheet A6V12815016 for the VWPG51.. series valves.

Modbus registers

Addr.	Reg.	Name	R/W	Range/Listing	Factory setting	Description
Process values						
0	1	Setpoint Heating	RW	0...100 % = 0...10000	0 %	Heating setpoint through the actuator
1	2	Override Control	RW	0 = Off / 2 = Close / 3 = Stop / 6 = MaxLimitHeating / 7 = MaxPositionHeating / 8 = MaxLimitCooling / 9 = MaxPositionCooling	0	Actuator's operation overriding the control signal
2	3	Actual Position Heating	R	0...100 % = 0...10000	-	Heating feedback position
3	4	Setpoint Cooling	RW	0...100 % = 0...10000	0 %	Cooling setpoint through the actuator
4	5	Actual Position Cooling	R	0...100 % = 0...10000	-	Cooling feedback position
5	6	Actual Flow Heating	R	0...MaxFlow [l/h]	-	Heating flow indication MaxFlow depends on Reg. 271 "Valve Model Type"
6	7	Actual Flow Cooling	R	0...MaxFlow [l/h]	-	Cooling flow rate indication MaxFlow depends on Reg. 271 "Valve Model Type"
7	8	Temperature State	R	0 = Heating / 1 = Cooling / 2 = Neither	-	Actual operational mode
255	256	Actuator Command	RW	0 = Ready / 1 = Calibrate Adaption / 2 = Self Test / 3 = Reinitialize Device / 4 = Factory Reset	0	Invoke special operation commands

Parameter						
256	257	Direction	RW	0 = CW / 1 = CCW	1	Actuator's rotation direction
258	259	Operating Mode	R	1 = Pos / 3 = 6WV	3	Actuator's operating mode
259	260	Max. Limit Heating	RW	0...100 % = 0...10000	100 %	Heating presetting
260	261	Max. Limit Cooling	RW	0...100 % = 0...10000	100 %	Cooling presetting
261	262	Running Time Actuator	R	150 [s]	150 s	Actuator's running time
263	264	Tolerance Blockade Monitoring	R	0...100 % = 0...10000	4 %	Allowed tolerance between setpoint and position in steady state
264	265	Max. Position Heating	RW	0...100 % = 0...10000	Depends on Reg. 270 "Valve Series Type"	Actuator's position reaching heating maximum flow based on selected valve type
265	266	Min. Position Heating	RW	0...100 % = 0...10000	Depends on Reg. 270 "Valve Series Type"	Actuator's position reaching heating minimum flow based on selected valve type
266	267	Closed Position	RW	0...100 % = 0...10000	Depends on Reg. 270 "Valve Series Type"	Actuator's position reaching no flow based on selected valve type

Parameter						
267	268	Min. Position Cooling	RW	0...100 % = 0...10000	Depends on Reg. 270 "Valve Series Type"	Actuator's position reaching cooling minimum flow based on selected valve type
270	269	Max. Position Cooling	RW	0...100 % = 0...10000	Depends on Reg. 270 "Valve Series Type"	Actuator's position reaching cooling maximum flow based on selected valve type
269	270	Valve Series Type	RW	0 = None / 1 = VWPG51 / 2 = VWG41.10 / 3 = VWG41.20	1	Valve type selection
270	271	Valve Model Type	RW	0 = None / 1 = VWPG51.15L0.9 / 2 = VWPG51.15F1.2 / 3 = VWPG51.20F4.3	0	Valve model selection Only available if Reg. 270 "Valve Series Type" = 1 [VWPG51]
512	513	Backup Mode	RW	0 = BackupPosition / 1 = Keep / 2 = Disabled	2 = Disabled	Pre-defined actuator position in case no bus communication is detected for the duration of "Backup Timeout" (Reg. 515)
513	514	Backup Position	RW	0...100 % = 0...10000	50 %	Backup position selection
514	515	Backup Timeout	RW	60...900 [s]	900 s	Backup timeout value selection
515	516	Startup Setpoint	RW	0...100 % = 0...10000	50 %	Actuator's setpoint at startup
763	764	Modbus Address	RW	1...248 / 255 = "Unassigned"	246 = AutoAddressing mode 248 → 255 = Unassigned	When trying to set the value at 248, it is automatically set to 255 instead
764	765	Baud Rate	RW	0 = Auto / 1 = 9600 / 2 = 19200 / 3 = 38400 / 4 = 57600 / 5 = 76800 / 6 = 115200	0	
765	766	Transmission Format	RW	0 = 1-8-E-1 / 1 = 1-8-O-1 / 2 = 1-8-N-1 / 3 = 1-8-N-2	0	
766	767	Bus Termination	RW	0 = Off / 1 = On 120 Ω electronically switchable	0	
767	768	Bus Conf. Command	RW	0 = Ready / 1 = Load / 2 = Discard	0	Load/discard Modbus settings
768	769	State	R	See Register 769 "State"	-	Service flags, as explained in Register 769 "State"

Device information			
1281	Factory index	R	2 bytes, each coding an ASCII char. making up the index
1282-83	Manufacturing date	R	2 bytes each, coding the date (hex)
1284-85	Serial number	R	2 bytes each, coding (hex) the serial no. (dec)
1409-16	ASN [characters 16..1] = actuator type	R	2 bytes each, each coding an ASCII char. making up the type

Register 769 "State"

Status			
Bit 00	1 = Not available	Bit 06	1 = Not available
Bit 01	1 = Backup mode active	Bit 07	1 = Not available
Bit 02	1 = Not available	Bit 08	1 = Not available
Bit 03	1 = Not available	Bit 09	1 = Self-test failed
Bit 04	1 = Mechanical fault, device jammed or manual override ¹⁾ or calibrating ¹⁾	Bit 10	1 = Self-test successful
Bit 05	1 = Not available	Bit 11	1 = Not available

¹⁾ After 10 seconds

Supported function codes

Function codes	
03 (0x03)	Read holding register
04 (0x04)	Read input registers
06 (0x06)	Write single register
16 (0x10)	Write multiple registers (Limit: Max. 120 registers within one write operation)

Communication properties

Communication		
Communication protocol	Modbus RTU	RS-485, not galvanically isolated
	Number of nodes	Max. 32
	Address range	1...248 / 255
	Factory setting	255
	Transmission formats	1-8-E-1, 1-8-N-1, 1-8-O-1, 1-8-N-2
	Factory setting	1-8-E-1
	Baud rates (kBaud)	Auto / 9.6 / 19.2 / 38.4 / 57.6 / 78.4 / 115.2
	Factory setting	Auto
	Bus termination	120 Ω electronically switchable
	Factory setting	Off

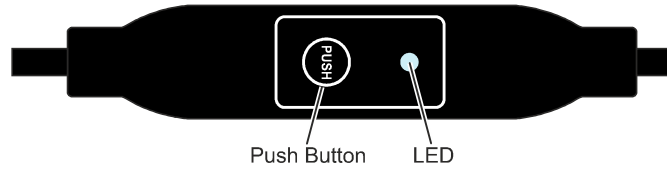

Pushbutton operation

Action	Pushbutton operation	Feedback message	
Return current Modbus address (starting from lowest address position)	Press button < 1 s	<ul style="list-style-type: none"> • 1st digit (single digit): red • 10-digit (double digit): green • 100-digit (triple digit): orange LED blinks blue 1 x after the address indication if bus termination is switched on. Example: 124 = 4 x red, 2 x green, 1 x orange	
Switch on/off bus termination			
	Switch on	Press button 3 x	Blinking or flashing of LED stops (termination mode).
		Briefly press button 1 x	Blue LED flashes 1 x.
		Hold button until the LED turns red	Red LED is lit (confirmation).
		Release button	LED not lit. Address is indicated. LED blinks blue 1 x after the address indication. Device enters normal mode.
	Switch off	Press button 3 x	Blinking or flashing of LED stops (termination mode).
		Briefly press button 1 x	Red LED is lit (confirmation).
Release button		Device enters normal mode.	
Enter Modbus address using pushbutton	Press button > 1 s and < 5 s	See "Pushbutton addressing"	
Enable pushbutton addressing (together with Climatix™ controllers)	Press button > 5 s and < 10 s	Red LED is lit and goes off after 5 s.	
	Release button	Orange LED lit.	
Reset to factory settings	Press button > 10 s	LED flashes orange.	

LED colors and flashing patterns

Color	Blinking pattern	Description
Green	1 s on / 5 s off	Normal mode without bus traffic
	Flickering	Normal mode with bus traffic
Orange / green	1 s orange / 1 s green	Device is in override control mode
Orange	1 s on / 1 s off	Bus parameter not yet configured
	1 s on / 5 s off	Device is in backup mode (replacement mode)
Red	Permanently lit	Mechanical error, device blocked, manual intervention or calibration
	1 s on / 5 s off	Internal error
	0.1 s on / 1 s off	Invalid configuration, e.g. Min = Max
Blue	Flickers 1 x after indicating the address	Bus termination active

Resetting the actuator by pushbutton

1. Hold button > 10 s.
 - LED flashes **orange**.
2. Release button *while* LED is still flashing.
 - LED flashes another 3 s.
3. Press button *within* these 3 s.
 - Reset is cancelled.
4. Press button *after* these 3 s.
 - ⇒ LED is **red** (Reset) while the device restarts.

Pushbutton addressing

Display current address (digits in reverse order)

The Modbus address can be set without an extra tool using pushbutton addressing. To display the current Modbus address, press the button < 1 s.

Colors		
1-digit: red	10-digit: green	100-digit: orange
Example for address 124 :		
LED		
Note	The address is entered and displayed beginning at the lowest digit (1st digit), see figure above. (Example: 124 starts with 4 x red)	

Set new address (digits in reverse order)

1. **Enable addressing mode:** Press button > 1 s.
 - LED is **red**.
 - Release pushbutton (before LED turns off).
 2. **Enter digits:** Press button n-times.
 - LED flashes 1 x for each press of the button as feedback.
1st digit: **red** / 2nd digit: **green** / 3rd digit: **orange**.
 3. **Save digits:** Hold pushbutton.
 - LED lights in the color of the following digits.
 - Release pushbutton.
 4. **Save address:** Hold pushbutton.
 - LED is **red** (confirmation).
 - Release pushbutton.
- ⇒ The entered address is indicated again 1 x for confirmation.



The address is discarded if the button is released before the LED lights red.

Examples

Set address "124":

1. Enable addressing mode.
 2. Set 1-digit: Press button 4 x.
 - LED flashes **red** for each press of the button.
 3. Save 1-digit: Hold button.
 - LED is lit **green**.
 - Release button.
 4. Set 10-digit: Press button 2 x.
 - LED flashes **green** for each press of the button.
 5. Save 10-digit: Hold button.
 - LED is lit **orange**.
 - Release button.
 6. Set 100-digit: Press button 1 x.
 - LED flashes **orange** for each press of the button.
 7. Save address: Hold button.
 - LED is lit **red**.
 - Release button.
- ⇒ The address is saved and is repeated 1 x for confirmation.

Set address "50":

1. Enable addressing mode.
 2. Skip 1-digit: Hold button.
 - LED is lit **green**.
 - Release button.
 3. Set 10-digit: Press button 5 x.
 - LED flashes **green** for each press of the button.
 4. Save address (skip 100-digit): Hold button.
 - LED is lit **red**.
 - Release button.
- ⇒ The address is saved and is repeated 1 x for confirmation.

Set address "5":

1. Enable addressing mode.
 2. Set 1-digit: Press button 5 x.
 - LED flashes **red** for each press of the button.
 3. Save address (skip 10-digit and 100-digit): Hold button.
 - LED is lit **red**.
 - Release button.
- ⇒ The address is saved and is repeated 1 x for confirmation.

Power supply			
Operating voltage (SELV/PELV) / Frequency		GDB161.9../6W GDB161.9../6P	AC 24 V ~ ± 20 % (19.2...28.8 V ~) / 50/60 Hz DC 24...48 V = ± 20 % (19.2...57.6 V =) ¹⁾
		GDB161.9E/MO6P	AC 24 V ~ ± 20 % (19.2...28.8 V ~) / 50/60 Hz DC 24 V = ± 20 % (19.2...28.8 V =)
Power consumption	Running	GDB161.9../6W GDB161.9../6P	2.1 VA / 1.2 W
		GDB161.9E/MO6P	2.6 VA / 1.7 W
	Holding	GDB161.9../6W GDB161.9../6P	0.7 W
		GDB161.9E/MO6P	1.2 W

¹⁾ cUL: Permitted only to DC 30 V =

Function data	
Nominal torque	5 Nm
Maximum torque (when blocked)	10 Nm
	Minimum holding torque
Nominal rotation angle (with position indication)	90°
Maximum rotation angle (mechanically limited)	95° ± 2°
Runtime at nominal rotational angle 90°	150 s
Permissible medium temperature in the valve in combination with GDB.. actuators	0...120 °C s
Actuator sound power level	28 dB(A)

Inputs	
Positioning signal for GDB161.9../6..	
Input voltage	(wires 8-2/Y-G0)
Current consumption	0.1 mA
Input resistance	> 100 kΩ
Max. permissible input voltage	DC 35 V = limited to DC 10 V =
Protected against faulty wiring	Max. AC 24 V ~ / DC 24...48 V =
Hysteresis	45 mV

Outputs		
Position indicator (GDB161.9../6..)		
Output signal	(Wires 9-2/U-G0)	
Output voltage U		DC 0...10 V =
Max. output current		DC ± 1 mA
Protected against faulty wiring		Max. AC 24 V ~ / DC 24...48 V =

Communication GDB161.9E/MO6P		
Communication protocol		
Modbus RTU		RS-485, not galvanically isolated
Number of nodes		Max. 32
Address range		1...248 / 255
	Factory setting	255
Transmission formats		1-8-E-1 / 1-8-O-1 / 1-8-N-1 / 1-8-N-2
	Factory setting	1-8-E-1
Baud rates (kBaud)		Auto / 9.6 / 19.2 / 38.4 / 57.6 / 76.8 / 115.2
	Factory setting	Auto
Bus termination		120 Ω electronically switchable
	Factory setting	Off

Connection cables		
Cable length	GDB161.9E/6W GDB161.9E/6P GDB161.9E/MO6P	0.9 m
	GDB161.9G/6W GDB161.9G/6P	3 m
	GDB161.9H/6W GDB161.9H/6P	5 m
Cable cross-section		0.75 mm ²
Permissible length for signal lines	GDB161.9E/6W GDB161.9E/6P	10 m
	GDB161.9E/MO6P	300 m

Degree of protection		
Insulation class		As per EN 60730
	AC 24 V ~ / DC 24...48 V =, feedback potentiometer	III
Housing protection		IP54 as per EN 60529

Ambient conditions		
Operation		As per IEC 60721-3-3
	Climatic conditions	Class 3K5
	Mounting location	Interior, weather-protected
	Temperature (extended)	-32...55 °C
	Humidity (non-condensing)	< 95 % r.h.
Transportation		As per IEC 60721-3-2
	Climatic conditions	Class 3K5 / Class 2K3
	Temperature (extended)	-32...70 °C
	Humidity (non-condensing)	< 95 % r.h.
Storage		As per IEC 60721-3-1
	Climatic conditions	Class 1K3
	Temperature (extended)	-32...50 °C
	Humidity (non-condensing)	< 95 % r.h.
Mechanical ambient conditions		Class 2M2

Standards, directives and approvals		
Product standard		EN 60730 Part 2-14: Particular requirements for electric actuators
Electromagnetic compatibility (Applications)		For residential, commercial, light-industrial and industrial environments
EU conformity (CE)		A5W00003842 ²⁾
RCM conformity		A5W00003843 ²⁾
EAC Conformity		Eurasian conformity
UL	UL	As per UL 60730 http://ul.com/database
	cUL	As per CSA-C22.2 No. 24-93
UKCA		A5W00198029A ²⁾

Environmental compatibility	
The product environmental declaration A5W00026068 ²⁾ contains data on environmentally compatible product design and assessments (RoHS compliance, materials composition, packaging, environmental benefit, disposal).	

Dimensions	
Actuator W x H x D	see Dimensions [▶ 25]

Weight	
Excl. packaging	0.69 kg
External Modbus converter	0.15 kg

²⁾ Documents can be downloaded at <http://www.siemens.com/bt/download>

Internal diagrams

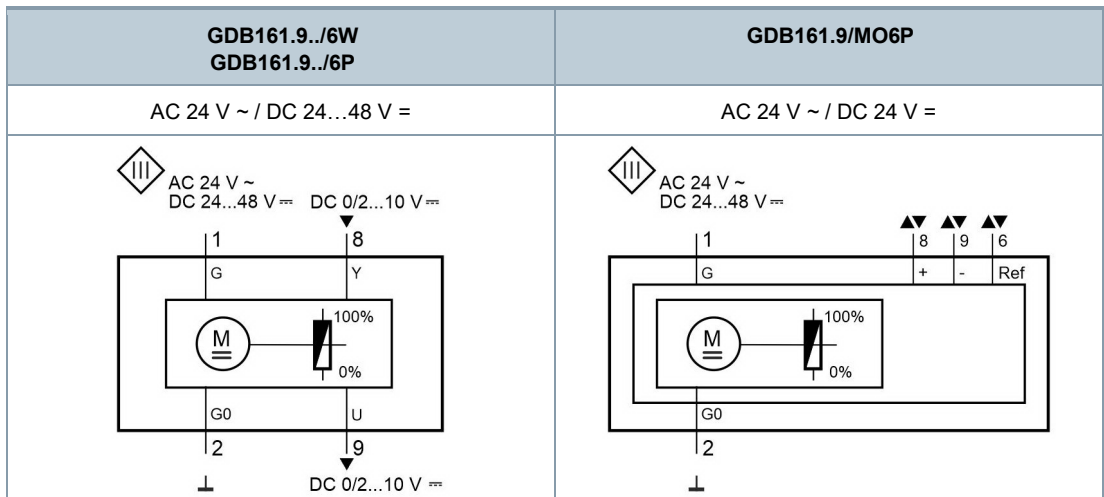

Connection diagrams

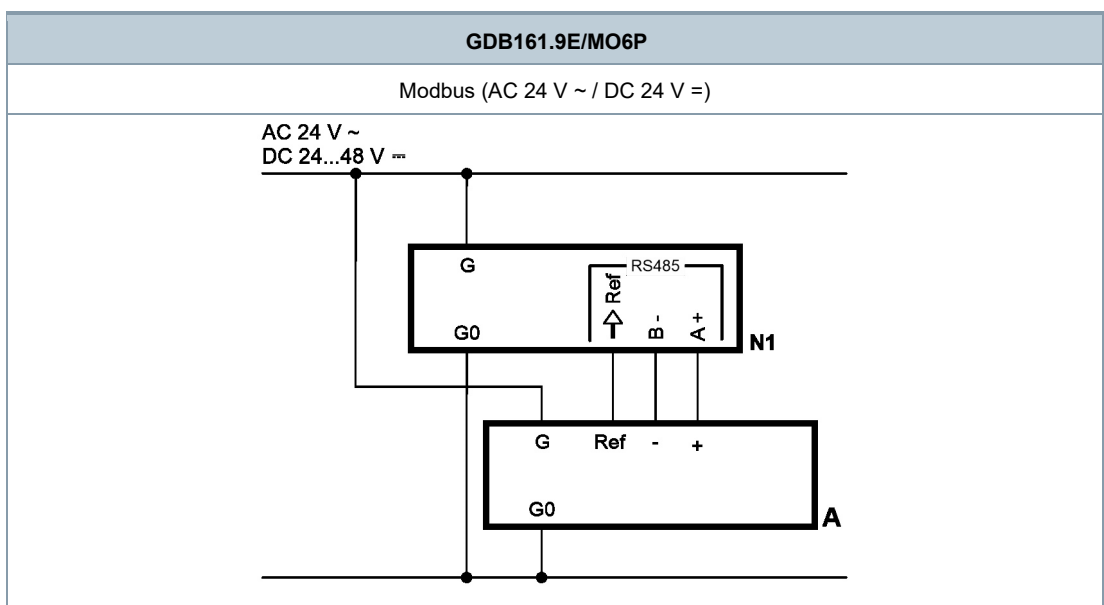
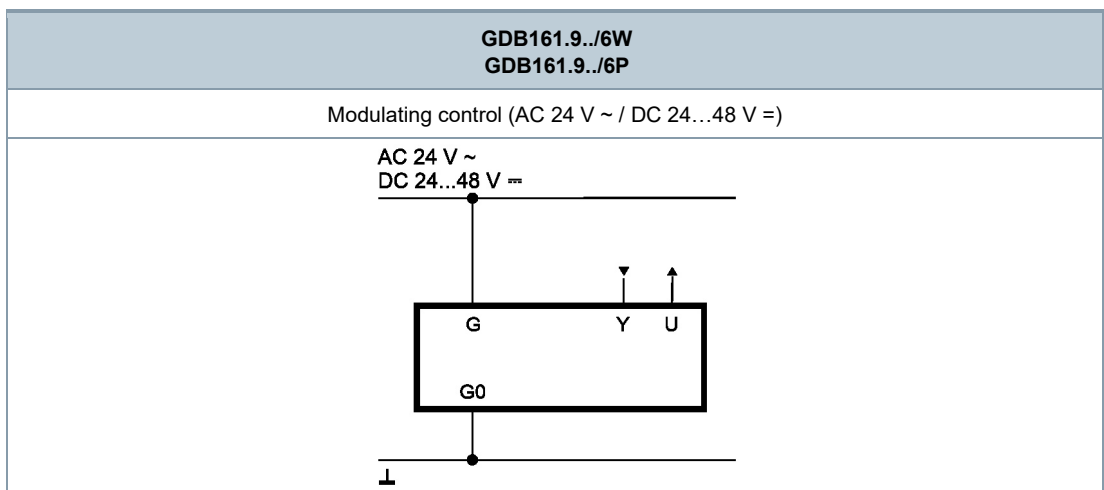

Cable designations

Connecting thread	Cable				Meaning
	Code	No.	Color	Abbreviation	
Rotary actuators AC 24 V ~ / DC 24...48 V =	G	1	Red	RD	System potential AC 24 V ~ / DC 24 V...48 V =
	G0	2	Black	BK	System neutral
	Y	8	Grey	GY	Signal in (GDB161.9../6..)
	U	9	Pink	PK	Signal out (GDB161.9../6..)
Modbus AC 24 V ~ / DC 24 V =	REF	6	Purple	VT	Reference line (Modbus RTU)
	+	8	Grey	GY	Bus + (Modbus RTU)
	-	9	Pink	PK	Bus - (Modbus RTU)

Dimensions

Actuator

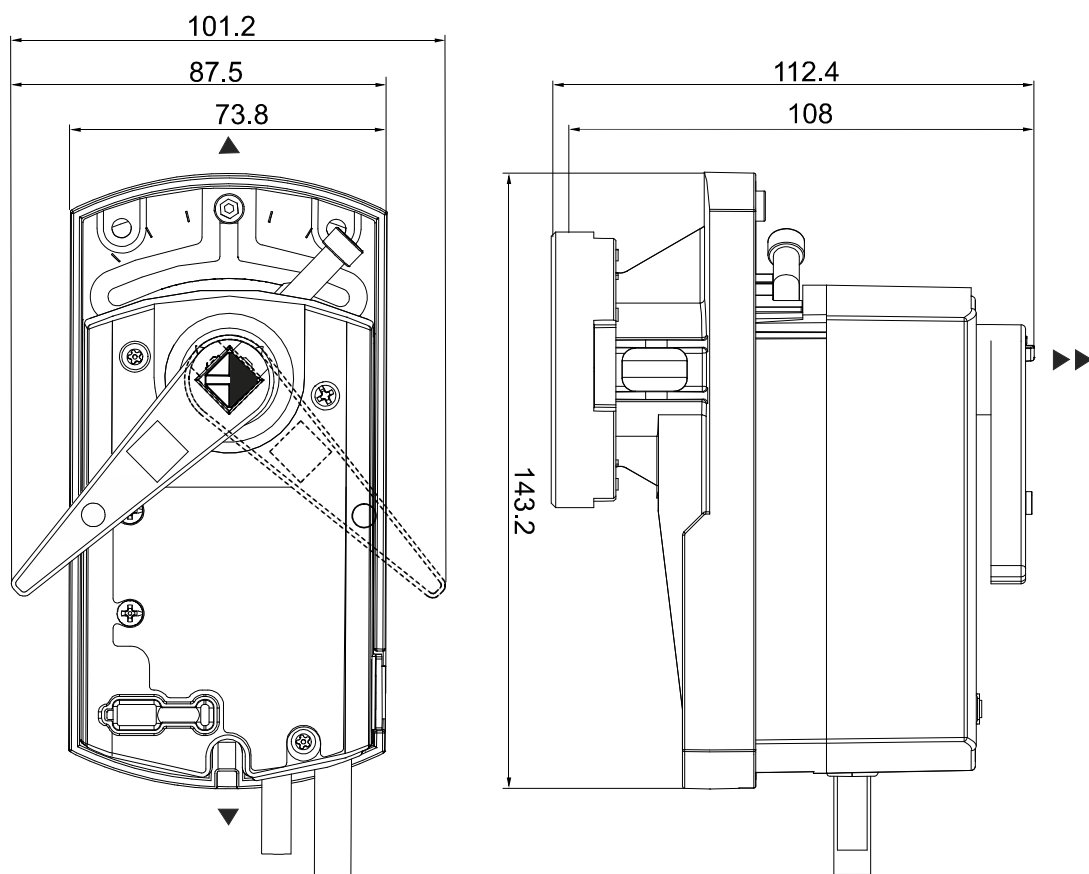

Dimensions in mm

- ▶ => 100 mm Min. clearance from ceiling or wall for mounting, connection, operation, maintenance, etc.
- ▶▶ => 36 mm

External Modbus converter

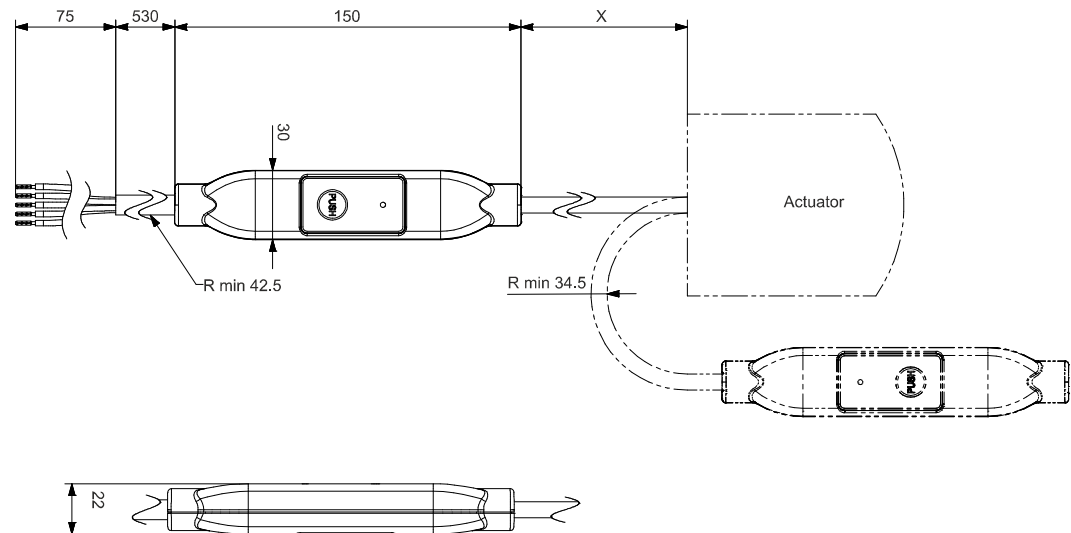

Revision numbers

Type	Valid from rev. no.
GDB161.9E/6W S55499-D784	..A
GDB161.9G/6W S55499-D829	..A
GDB161.9H/6W S55499-D830	..A
GDB161.9E/6P S55499-D801	..A
GDB161.9G/6P S55499-D827	..A
GDB161.9H/6P S55499-D828	..A
GDB161.9E/MO6P S55499-D802	..A

Issued by
Siemens Switzerland Ltd
Smart Infrastructure
Global Headquarters
Theilerstrasse 1a
CH-6300 Zug
+41 58 724 2424
www.siemens.com/buildingtechnologies

© Siemens 2022
Technical specifications and availability subject to change without notice.

Document ID A6V12986395_en--_c
Edition 2023-05-22