

Rotary actuators for ball valves

GMA..9E..



Electromotive rotary actuators with spring return for fail-safe function on 2-position, 3-position, and modulating control. Used on heating, ventilation, and air conditioning plants

- For 2-port and 3-port control ball valves, internally threaded connections (VAI61.. and VBI61..) or externally threaded connections (VAG61.. and VBG61..), DN15 to DN50.
- For open/close ball valves 2-port and changeover ball valves 3-port, internally threaded connections (VAI60.. and VBI60..) or externally threaded connections (VAG60.. and VBG60..), DN15 to DN50.
- Nominal torque 7 Nm
- GMA1..1.9E: Operating voltage AC 24 V / DC 24...48 V
- GMA161.9E/MO: Operating voltage AC 24 V / DC 24 V
- GMA321.9E: Operating voltage AC 230 V ~
- Positioning signal DC 0/2...10 V=
- GMA161.9E/MO: RS-485 for Modbus RTU communication
- Prewired with 0.9 m connecting cable

Features

- Brushless, robust DC motors ensure reliable operation regardless of load.
- The valve actuators do not require an end position switch, are overload proof, and remain in place upon reaching the end stop.
- The gears are maintenance free and low noise.
- Suitable for use with modulating (DC 0...10 V), 2-position or 3-position controllers.
- We recommend a minimum pulse length of 500 ms on rotary actuators operated with 3-point control to ensure continuous and accurate operation.
- On plants where the rotary actuator must move to the zero position (emergency position) during power failure.

Functions

Type ¹⁾	GMA..21.9E	GMA131.9E	GMA161.9E	GMA161.9E/MO
Control type	2-position	3-position	Modulating	Modbus RTU
Rotary direction as per mounting on ball valve	NC (normally closed) ball valve	NC (normally closed) ball valve	NC (normally closed) ball valve	
	Switch on operating voltage: <ul style="list-style-type: none"> • Actuator opens Switch off operating voltage: <ul style="list-style-type: none"> • Actuator closes with spring return (clockwise) 	Signal to Y1 <ul style="list-style-type: none"> • – rotation counter-clockwise • – ball valve opens Signal to Y2 <ul style="list-style-type: none"> • – rotation clockwise • – ball valve closes 	0...10 V "counter-clockwise" Flow = 0% at Y = 0 V Flow = 100% at Y = 0 V	0...100% "counter-clockwise" Flow = 0% at Reg. 1 = 0 Flow = 100% at Reg. 1 = 10.000
See mounting instructions M4658 for other switchings.				
Emergency position (Spring return)	On power failure or when the operating voltage is switched off, the spring moves the rotary actuator to its mechanical zero position.			
Position indication: Mechanical	Rotary angle position indication as position indicator. ²⁾			
Position indication: Electrical			Output voltage U = DC 0 to 10 V is generated proportional to rotary angle..	
Manual adjustment	<ul style="list-style-type: none"> • Without voltage supplied, the rotary actuator can be rotated and fixed in any position using the supplied Allen wrench. • The rotary actuator returns to the zero position (actuator closed) if mechanically unlocked with an Allen wrench or via short-term voltage 			
Modbus RTU (RS-485), not galvanically isolated				Setpoint 0...100 % valve setting Actual value 0...100 % for valve position forced control open / close / Min / Max / Stop Setpoint monitoring and backup mode

1) When combining GMA..1E and ASK77.2: Carefully read mounting instructions M4696 (74 319 0648 0)!

2) Manual adjustment of the position indicator can cause damage to the unit.

Technical design

Housing

The housing is made of aluminum:

- Flame retardant

Type summary

Type	Item NO.	Positioning signal	Operating voltage	Position indicator U = DC 0...10 V	Self-adaption Rotational angle area	Auxiliary switch	Rotation direction switch
GMA121.9E	BPZ:GMA121.9E	2-position	AC 24 V ~ / DC 24...48 V =	–	–	–	Yes
GMA321.9E	BPZ:GMA321.9E		AC 230 V ~	–	–	–	
GMA131.9E	BPZ:GMA131.9E	3-position	AC 24 V ~ / DC 24...48 V =	–	–	–	
GMA161.9E	BPZ:GMA161.9E	DC 0...10 V =	AC 24 V ~ / DC 24...48 V =	Yes	Yes	–	
GMA161.9E/MO	S55499-D683	Modbus RTU	AC 24 V ~ / DC 24 V =	Yes	Yes	–	

Accessories / spare parts

Accessories

⚠ DANGER	
	<p>Hazard to life caused by a lack of ground for the combination ALJ100 with GMA321.9E!</p> <p>Combining rotary actuator GMA321.9E operated at AC 230 V ~ with temperature adapter ALJ100 results in life-threatening shocks due to a lack of ground.</p> <ul style="list-style-type: none"> Never combine rotary actuator GMA321.9E with temperature adapter ALJ100.

Type	Stock number	Description
ALJ100	S55846-Z115	Temperature adapter for ball valves

Equipment combinations

Rotary actuators are suitable for operating following Siemens ball valves:

VA..61.. 2-port control ball valves

Control ball valves with:				k _{vs} [m ³ /h]	DN	GMA..9E..		
Internal threads ¹⁾	Rp	External threads ²⁾	G..B			Δp _{max}	Δp _s	
–	–	VAG61.15..	G 1 B	1...6.3	15	350	1400	
VAI61.15..	Rp ½"	–	–	0.25...10	15			
VAI61.20..	Rp ¾"	VAG61.20..	G 1 ¼ B	4...10	20			
VAI61.25..	Rp 1"	VAG61.25..	G 1 ½ B	6.3...16	25			
VAI61.32..	Rp 1¼"	VAG61.32..	G 2 B	10...25	32			1000
VAI61.40..	Rp 1½"	VAG61.40..	G 2 ¼ B	16...40	40			800
VAI61.50..	Rp 2"	VAG61.50..	G 2 ¾ B	25...63	50	600		

VB..61..
3-Port control ball valves

Control ball valves with:				k _{vs} [m ³ /h]	DN	GMA..9E..	
Internal threads ¹⁾	Rp	External threads ²⁾	G..B			Δp _{max}	Δp _s
VBI61.15..	Rp ½"	VBG61.15..	G 1 B	1.6...6.3	15	350	–
VBI61.20..	Rp ¾"	VBG61.20..	G 1 ¼ B	4...6.3	20		
VBG61.25-10	Rp 1"	VBG61.25-10	G 1 ½ B	10	25		
VBI61.32-16	Rp 1¼"	VBG61.32-16	G 2 B	16	32		
VBI61.40-25	Rp 1½"	VBG61.40-25	G 2 ¼ B	25	40		
–	–	VBG61.50-40	G 2 ¾ B	40	50		
VBI61.50..	Rp 2"	–	–	40...63	50		

¹⁾ Data sheet N4211

²⁾ Data sheet N4212

VA..60.. / VB..60..
2-port shut-off valves and 3-port changeover ball valves

Control ball valves with:				k _{vs} [m ³ /h]	DN	GMA..9E..		
Internal threads ³⁾	Rp	External threads ⁴⁾	G..B			Δp _{max}	Δp _s	
–	–	VAG60.15-9	G 1 B	9	15	350	1400	
VAI60.15-15	Rp ½"	–	–	15	15			
–	–	VAG60.20-17	G 1 ¼ B	17	20			
VAI60.20-22	Rp 1"	–	–	22	20			
VAI60.25-22	Rp 1"	VAG60.25-22	G 1 ½ B	22	25			
VAI60.32-35	Rp 1¼"	VAG60.32-35	G 2 B	35	32			1000
VAI60.40-68	Rp 1½"	VAG60.40-68	G 2 ¼ B	68	40			800
VAI60.50-96	Rp 2"	VAG60.50-96	G 2 ¾ B	96	50	600		

VBI60.15-5L	Rp ½"	VBG60.15-5L	G 1 B	5	15	350	–
–	–	VBG60.20-8L	G 1 ¼ B	8	20		
VBI60.20-9L	Rp 1"	–	–	9	20		
VBI60.25-9L	Rp 1"	VBG60.25-9L	G 1 ½ B	9	25		
VBI60.32-13L	Rp 1¼"	VBG60.32-13L	G 2 B	13	32		
VBI60.40-25L	Rp 1½"	VBG60.40-25L	G 2 ¼ B	25	40		
VBI60.50-37L	Rp 2"	VBG60.50-37L	G 2 ¾ B	37	50		

–	–	VBG60.15-8T	G 1 B	8	15	350	–
VBI60.15-12T	Rp ½"	–	–	12	15		
–	–	VBG60.20-13T	G 1 ¼ B	13	20		

VBI60.20-16T	Rp 1"	–	–	16	20		
–	–	VBG60.25-13T	G 1 ½ B	13	25		
VBI60.25-16T	Rp 1"	–	–	16	25		
VBI60.32-25T	Rp 1¼"	VBG60.32-25T	G 2 B	25	32		
VBI60.40-49T	Rp 1½"	VBG60.40-49T	G 2 ¼ B	49	40		
VBI60.50-73T	Rp 2"	VBG60.50-73T	G 2 ¾ B	73	50		

³⁾ Data sheet N4213

⁴⁾ Data sheet N4214

Product documentation

Topic	Title	Document ID
Data sheet	Rotary actuators for ball valves	N4658
Mounting instructions	GMA..9E..	M4658
Mounting instructions	VAI61 / VBI61..	M4211
Mounting instructions	VAG61 / VBG61..	M4212
Mounting instructions	VAI60.. / VBI60..	M4213
Mounting instructions	VAG60.. / VBG60..	M4214

Related documents such as the environmental declarations, CE declarations, etc., can be downloaded from the following Internet address:

<https://siemens.com/bt/download>

Notes

Additional information on rotary actuators is available in document Z4614.

Safety

⚠ CAUTION	
	<p>National safety regulations</p> <p>Failure to comply with national safety regulations may result in personal injury and property damage.</p> <ul style="list-style-type: none"> • Observe national provisions and comply with the appropriate safety regulations. • Mounting, commissioning, and service by properly trained personnel only.

Engineering

We recommend using temperature adapter ALJ100 in locations exposed to condensation to protect the actuator. Lubricate the adapter axle with silicon grease at medium temperatures $\leq 0\text{ }^{\circ}\text{C}$.

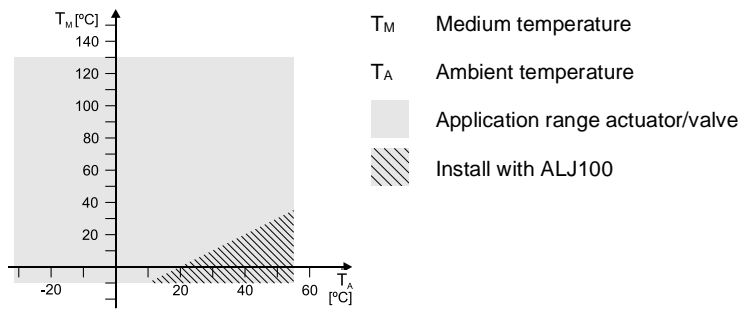

GMA161.9E/MO

The Modbus converter is designed for analog control at 0...10 V.

Mounting

Both ball valve and rotary actuator can be easily and directly assembled at the mounting location. No special tools or adjustments required.

Alignment

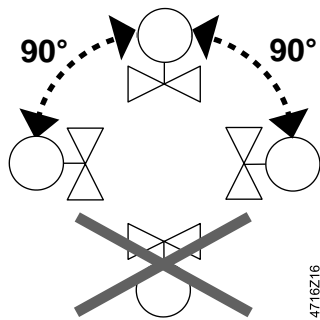

Installation

⚠ WARNING



No internal line protection for supply lines to external consumers

Risk of fire and injury due to short-circuits!

- Adapt the wire cross sections as per local regulations to the rated value of the installed fuse.

Commissioning

When commissioning the system, check both wiring and rotary actuator functions.

Maintenance

GMA..9E.. actuators are maintenance-free.

⚠WARNING



Tensioned return spring

Opening the drive housing can release the highly tensioned return spring, possibly resulting in injury due to flying parts.

- Do not open the drive housing.

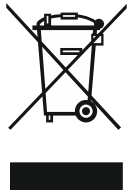

The device is considered an electronic device for disposal in accordance with European guidelines and may not be disposed of as domestic waste.

- Dispose of the device through channels provided for this purpose.
- Comply with all local and currently applicable laws and regulations.

Warranty service

The application-specific technical data is guaranteed only in combination with the Siemens products listed in the 'Device combinations' section. If third-party products are used, any guarantee provided by Siemens will be invalidated.

Power GMA1..9E..			
Operating voltage AC		AC 24 V \pm 20 %	
Frequency		50/60 Hz	
Operating voltage DC		DC 24...48 V \pm 20 %	
Power consumption	Operation	AC: 5 VA / 3.5 W	
		DC: 3.5 W	
	Hold	GMA121.9E / GMA131.9E	AC / DC: 2 W
		GMA161.9E..	AC / DC: 2,5 W

Power GMA321.9E		
Operating voltage		AC 230 V \pm 10 %
Frequency		50/60 Hz
Power consumption	Operation	7 VA / 4.5 W
	Hold	3.5 W

Function data		
Nominal torque		7 Nm
	Maximum torque (when blocked)	21 Nm
	Minimum holding torque	4 Nm
Nominal rotation angle (with position indication)		90°
	Maximum rotation angle (mechanically limited)	95° \pm 2°
Runtime at nominal rotational angle 90°		90 [s]
Closing time with spring return (on power failure)		15 s

Inputs GMA1..9E..			
Positioning signal			
	Switching current (at AC 24 V / DC 24...48 V =) for "Open"/"Close"		> AC / DC 8 mA
	Input voltage Y	(wires 8-2)	DC 0...10 V =
	Max. permissible input voltage		DC 35 V
		(Wires 9-2)	DC 0...10 V =
	Max. output current		DC \pm 1 mA

Communication GMA161.9E/MO		
Communication protocol		
	Modbus RTU	RS-485, not galvanically isolated
	Number of nodes	Max. 32
	Address range	1...248 / 255
	Factory setting	255
	Transmission formats	1-8-E-1 / 1-8-O-1 / 1-8-N-1 / 1-8-N-2
	Factory setting	1-8-E-1
	Baud rates (kbaud)	Auto / 9.6 / 19.2 / 38.4 / 57.6 / 76.8 / 115.2
	Factory setting	Auto
	Bus termination	120 Ω electronically switchable
	Factory setting	Off

Outputs GMA1..9E..		
Output signal		
	Output voltage U	(Wires 9-2) DC 0...10 V =
	Max. output current	DC ± 1 mA

Connection cables	
Cable length	0.9 m
Cable cross-section	0.75 mm ²

Ambient conditions and protection classification		
Device IP class per EN 60730		
	AC 24 V ~ / DC 24 V =	III
	AC 230 V ~	II
Degree of protection of housing to EN 60529		IP54
Operation		As per IEC 60721-3-3
	Climatic conditions	Class 2K3
	Temperature (extended)	-32...55 °C
	Humidity (non-condensing)	<95 % r.h.
Transportation		Transport per IEC 60721-3-2
	Climatic conditions	Class 3K5 / Class 2K3
	Temperature (extended)	-32...70 °C
	Humidity (non-condensing)	<95 % r.h.
Storage		Per IEC 60721-3-1
	Climatic conditions	Class 1K3

Ambient conditions and protection classification	
Temperature (extended)	-32...50 °C
Humidity (non-condensing)	<95 % r.h.
Mechanical ambient conditions	Class 2M2

Standards, directives and approvals	
Product standards	EN 60730 Part 2-14: Particular requirements for electric actuators
Electromagnetic compatibility (field of use)	For residential, commercial, and industrial environments
EU conformity (CE)	8000081792 ¹⁾
RCM conformity	8000081793 ¹⁾

Environmental compatibility
The product environmental declaration CE1E4614en ¹⁾ contains data on environmentally compatible product design and assessments (RoHS compliance, materials composition, packaging, environmental benefit, disposal).

Dimensions
See Dimensions [▶ 13]

Weight GMA1..9E..	
Excl. packaging	1.2 kg
External Modbus converter	0.15 kg

Weight GMA321.9E	
Excl. packaging	1.3 kg

¹⁾ Documents can be downloaded at <http://www.siemens.com/bt/download>

Internal diagrams

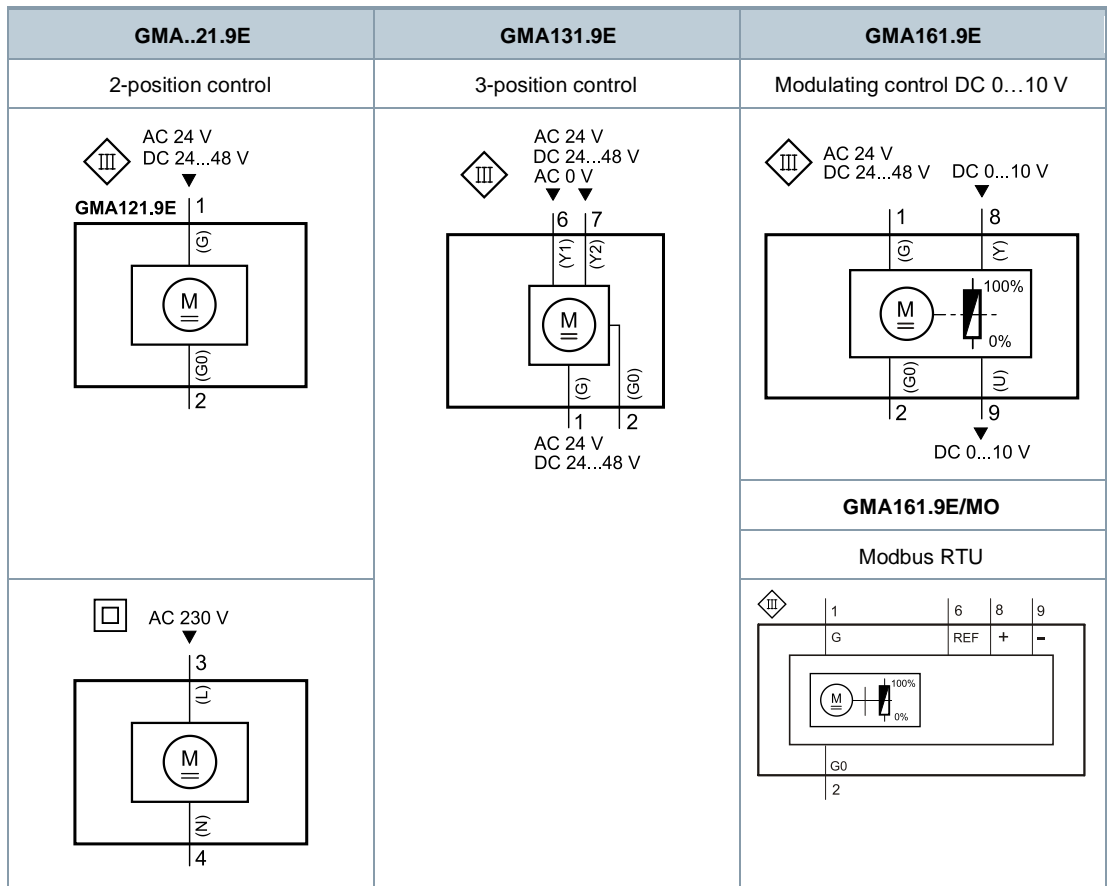

Connection diagrams

Single pole single throw (SPST)

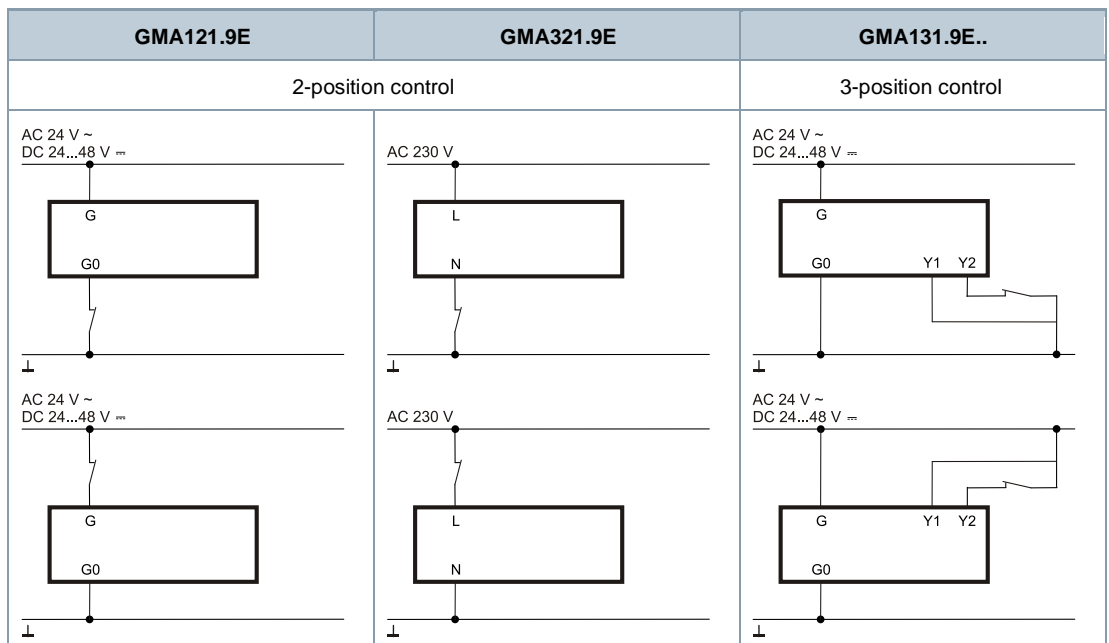

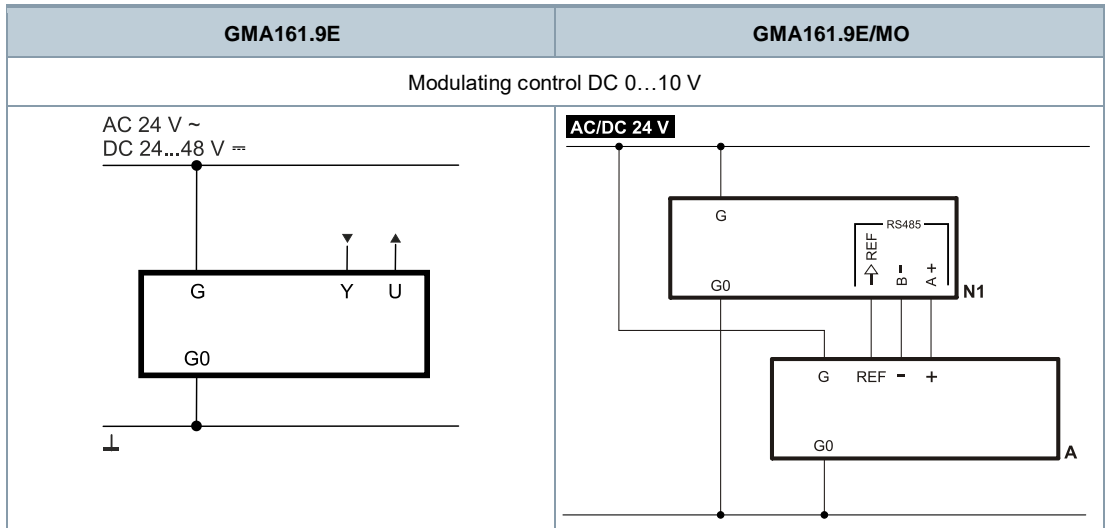

Cable designations

Connecting thread	Cable				Meaning
	Code	No.	Color	Abbreviation	
Rotary actuators AC 24 V ~ DC 24 V =	G	1	Red	RD	System potential AC 24 V ~ / DC 24 V...48 V =
	G0	2	Black	BK	System neutral
	Y1	6	Purple	VT	Positioning signal AC 0 V, AC 24 V ~ / DC 24...48 V = "Counter-clockwise" NC.
	Y2	7	Orange	OG	Positioning signal AC 0 V, AC 24 V ~ / DC 24...48 V = "Clockwise" NC.
	Y	8	Gray	GY	Positioning signal DC 0...10 V
Rotary actuators AC 230 V ~	U	9	Pink	PK	Position indication 0...10 VDC
	L	3	Brown	BN	Phase AC 230 V
Modbus AC 24 V ~ DC 24 V =	N	4	Blue	BU	Neutral conductor
	REF	6	Purple	VT	Reference line (Modbus RTU)
	+	8	Gray	GY	Bus + (Modbus RTU)
	-	9	Pink	PK	Bus - (Modbus RTU)

Actuator

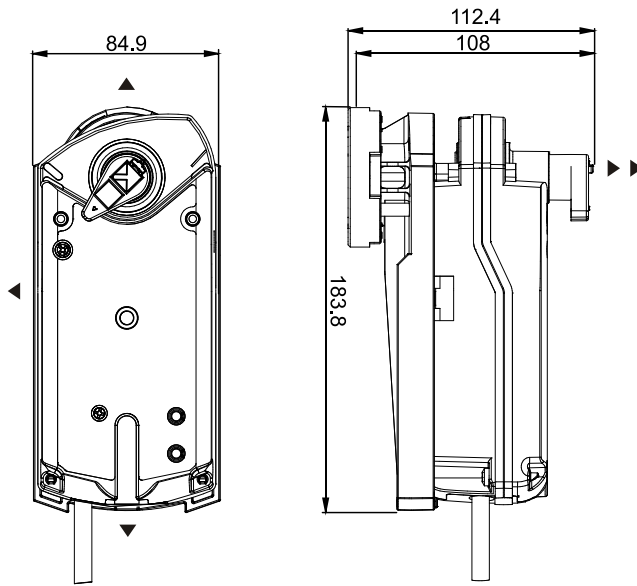

Dimensions in mm

- ▶ => 100 mm
- ▶ => 200 mm
- ▶

Min. clearance from ceiling or wall for mounting, connection, operation, maintenance, etc.

External Modbus converter

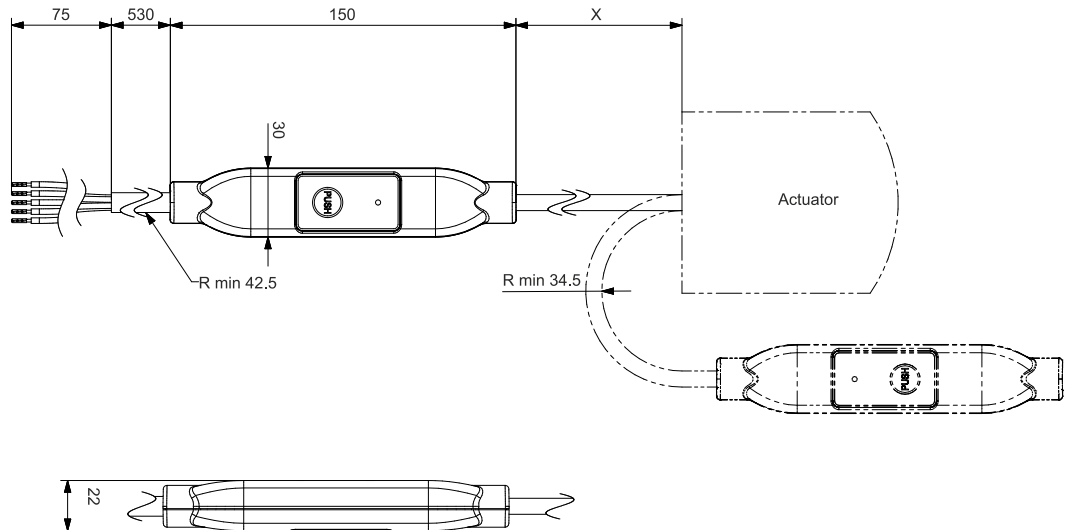

Temperature adapter (optional)

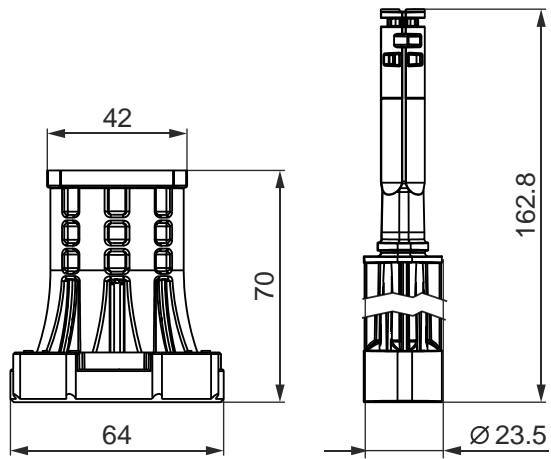

Revision numbers

Type	Valid from rev. no.
GMA121.9E	..B
GMA321.9E	..B
GMA131.9E	..B
GMA161.9E	..B
GMA161.9E/MO	..C

Issued by
Siemens Switzerland Ltd
Smart Infrastructure
Global Headquarters
Theilerstrasse 1a
CH-6300 Zug
+41 58 724 2424
www.siemens.com/buildingtechnologies

© Siemens Switzerland Ltd, 2021
Technical specifications and availability subject to change without notice.

Document ID CM2N4658en
Edition 2022-07-07